



交流低压三相异步电动机

AC Low Voltage Three Phase
Asynchronous Motor



西安西玛电机有限公司

XI'AN SIMO MOTOR CO.,LTD



精益

—
高品质

—
高效率

Enterprise Introduction

公司简介

西安西玛电机有限公司(原西安电机厂)是中国机械工业专业生产大中型、高低压、交直流电动机、同步电机、高效电机及防爆电机、高低压软起动装置、高低压变频装置、高低压电能质量装置、高低压调功装置、PLC自动化系统集成、同步电机励磁装置、伺服驱动、电源和高低压电气成套装置的研发制造企业,是集电机设计制造、机械加工和自动化成套工程为一体的动力系统提供商。

西玛公司始于1955年,已有60多年电机生产销售的历史。西玛电机于1995年在电机行业中率先取得了ISO9001-1994质量体系认证,2006年5月又通过了ISO14000环境管理体系和OHSAS18000职业健康安全管理体系认证,2017年通过了中国质量认证中心(CQC)的ISO9001-2015质量体系认证。

公司主导产品拥有发明专利120余项,并获得了欧盟“CE”、澳大利亚“GEMS”、韩国“KC”、俄罗斯“GOST”和中国“CCC”以及节能认证。防爆系列电机均取得防爆合格证、“CCC”强制性产品认证证书和矿用产品安全标志证书。

西玛电机拥有产品34大系列、1800多个品种、19500多个规格,功率范围从0.35千瓦至25000千瓦。主要电机产品有YX、YXKK、YXKS系列高效高压电动机,YR、YRKK、YRKS绕线高压电动机,YE3高效、YE4超高效系列异步电动机,YVFE2、YVFE3、YVFE4系列高效变频调速电动机,YB2、YBX2、YBX3、YBX4、YBK3、YBF3、YBBP系列隔爆型高低压异步电动机,T、TD、TK、TDMK系列同步电动机、TF350-5000KW系列大型同步发电机和Z2、Z4、Z系列直流电动机,广泛应用于环保、电力、煤炭、石油、采矿、冶金、铁路、交通、化工、农业、水利、航空、航海及高科技等领域,是中国铁路总公司定点的电机配套厂家,美国GE公司合格供应商。

西玛电机充分借鉴国内外同行业先进的管理模式,精益化管理生产经营,不断提高效率和质量水平,提升为客户提供全过程服务水平,增强市场竞争能力,满足客户日益提高的各种需求。

“西玛电机,做电机我们是认真的”!

Xi'an Simo Motor Co., Ltd. (The former Xi' an Motor Factory) is a company specializing in the researching and manufacturing of large and medium-sized, high and low voltage, AC and DC motors, synchronous motors, high-efficiency motors and explosion-proof motors, HV and LV soft starters, HV and LV frequency converters, HV and LV power quality devices, HV and LV power control devices, PLC automatic system integration, synchronous motor excitation equipments, servo drive, power supply and HV and LV electric complete equipments in China machinery industry. We are a power system supplier integrating motor design and manufacturing, mechanical processing and automation.

Founded in 1955 and we have a history of more than 60 years in motor manufacturing and selling market. In 1995, "Simo" brand products took the lead in obtaining ISO 9001-1994 quality system certification in motor industry. In May 2006, it acquired the certification of ISO14000 Environmental Management System and OHSAS18000 Occupational Health and Safety Management System. In 2017, it acquired the China Quality Certification Center (CQC) ISO 9001-2015 quality system certification.

We have more than 120 patents for invention and successively obtain certification of European "CE", American "UL", Australian "GEMS", Korean "KC", Russia "GOST" and China "CCC". As for Explosion-proof motors, we obtained explosion-proof certificate, CCC, as well as MA Verification.

We have 34 series of products, more than 1800 varieties and more than 19500 specifications with the power range from 0.35 kW to 25000 kW. The main motor products are YX, YXKK, YXKS series high-efficiency high-voltage motors, YR, YRKK, YRKS series winding high-voltage motors, YE3 high-efficiency series and YE4 ultra-high-efficiency asynchronous motors, YVFE2, YVFE3, YVFE4 series high efficiency variable frequency motors, YB2, YBX2, YB3, YBX3, YBX4, YBK3, YBF3, YBBP-series high-low voltage flameproof asynchronous motors, T, TD, TK, TDMK series synchronous motors, TF350-5000KW series large synchronous generator and Z2, Z4, Z series DC motor. They are all widely used in electric power, coal, petroleum, mining, metallurgy, railway, transportation, chemical industry, agriculture, water conservancy, aviation, navigation and high-tech fields. We are also the designated auxiliary motor supplier of the Ministry of Railways and GE.

Simo motor fully draws lessons from the advanced management mode of the same industry at home and abroad. We learn production and operation management, improves the efficiency and quality level constantly, enhances the whole process of customer service level, strengthens market competitiveness to meet the increasing needs of customers.

"SIMO motor, we are earnest in making motors"!

品质
决定生命

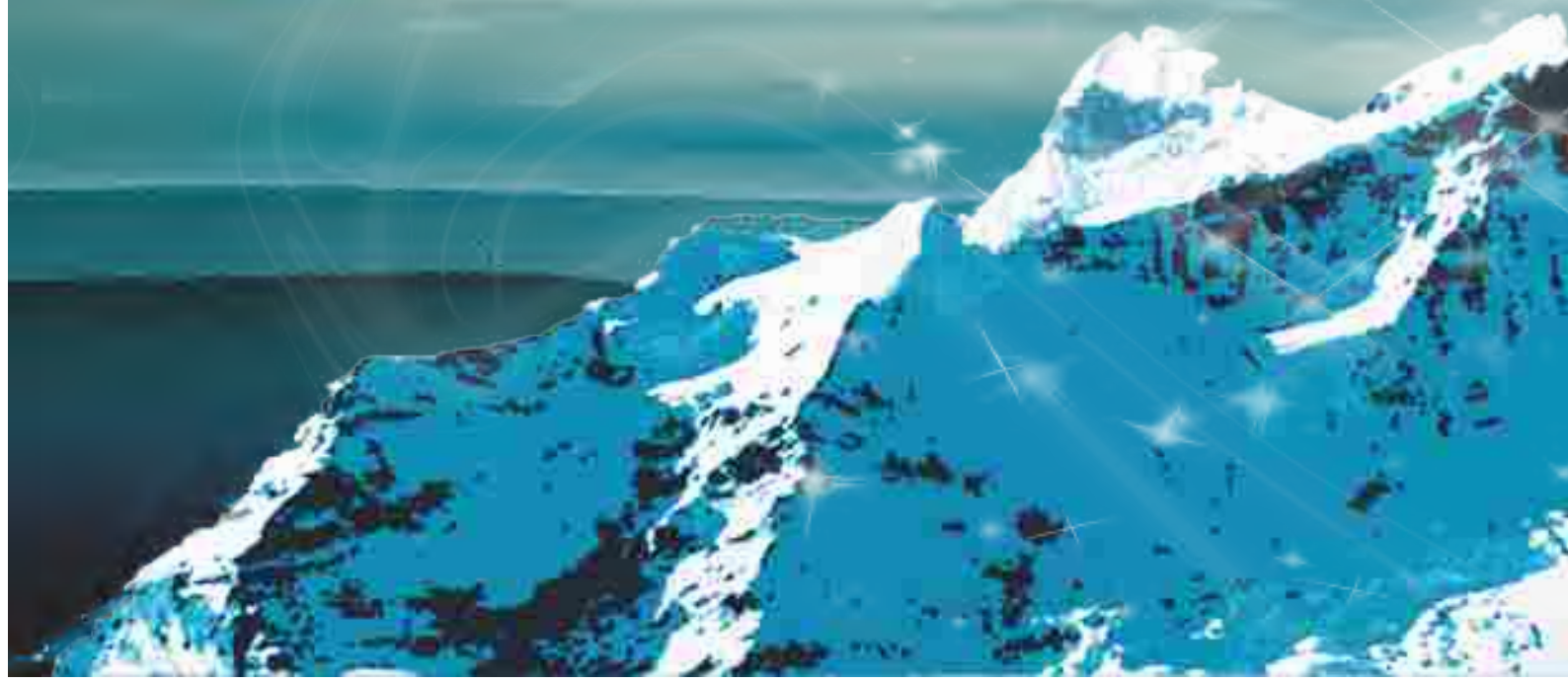

产品目录

Product Catalog

- 概述
Brief Description 01/07
- 电动机型谱
Motor Type 08/09
- 结构剖面示意图
Structural Section Diagram 10/11
- YE3/YE4/YE5系列三相异步电动机
YE3/YE4/YE5 Series Motor Three-Phase Asynchronous Motor 12/26
- YE3/YE4/YE5系列异步电动机安装及外形尺寸
YE3/YE4/YE5 Series Motor Mounting And Outline Dimension 27/35
- YVFE2/YVFE3/YVFE4/YVFE5系列三相异步电动机
YVFE2/YVFE3/YVFE4/YVFE5 Series Motor Three-Phase Asynchronous Motor 36/54
- YVFE2/YVFE3/YVFE4/YVFE5系列异步电动机安装及外形尺寸
YVFE2/YVFE3/YVFE4/YVFE5 Series Motor Mounting And Outline Dimension 55/63
- 订购指南
Ordering Guidelines 64/64
- 防伪查询
Anti-Counterfeiting Query 65/65



概述 Brief Description

系列高效三相异步电动机（中心高H80~H450）符合GB/T 755《旋转电动机 定额和性能》，其能效等级满足GB 18613《中小型三相异步电动机能效限定值及能效等级》及国际标准IEC 60034-30-1《单速三相笼型感应电动机效率分级》，效率由测量输入-输出功率的损耗分析法确定（按GB/T 1032中规定）。

系列电动机壳体均采用高强度灰铸铁制造，线圈采用优质的耐腐蚀铜线制作。外壳的防护等级为IP55，符合GB/T 4942.1及IEC 60034-5规定，安装尺寸符合IEC 60072国际标准及国标GB/T 4772.1，冷却方式为IC411和IC416，适用于连续工作制（S1）工作运行。具有损耗低、效率高、结构紧凑、运转平稳、振动小、噪声低、使用寿命长、使用维护方便等特点，可广泛应用于机床、水泵、风机、压缩机、减速机，也可适用于运输、搅拌、印刷、农机、食品等各类机械传动设备。

This series of high-efficiency three-phase asynchronous motors (center height H80 ~ H450) accords with GB/T 755 Rotating Electrical Machines-Ratings and Performance, and motors energy efficiency grade meets with GB 18613-2012 Minimum Allowable Values of Energy Efficiency and Energy Efficiency Grades for Small and Medium Three-phase Asynchronous Motors and the international standards IEC 60034-30-1 Energy Efficiency Class of Single-speed Three-phase Cage Induction Motors. The efficiency is determined by the loss analysis method of measuring input-output power (as specified in GB/T 1032).

This series of motor casings are made of high strengthened gray cast iron, the coil is made of high quality corrosion-resistant copper wire. The protection of the housing is IP55, which meets the requirements of GB/T4942.1 and IEC 60034-5. The mounting dimensions meet with the international standards of IEC 60072 and GB/T 4772.1, and the cooling types are IC411 and IC416. This series of motor are suitable for continuous working system (S1), having the characteristics of low loss, high efficiency, compact structure, stable operation, low vibration, low noise, long service life, convenient use and maintenance, etc. They can be widely mounted in machine tools, water pumps, fans, compressors, reducers, and also suitable for many mechanical transmission equipments, such as transportation, mixing, printing, agricultural machinery, food, etc.

标准技术特性 Standard Technical Characteristics

中心高 | Frame Size: H80 ~ H450

额定功率 | Rated Power: 0.18kW ~ 1000kW

极数 | No. Of Poles: 2极、4极、6极、8极、10极

额定电压 | Rated Voltage: 380V、400V、415V、660V、690V、220/380V、380/660V、400/690V等

额定频率 | Rated Frequency: 50Hz

工作制 | Duty: S1

热分级 | Insulation Grade: 155 (F) 级/Grade

安装型式 | Mounting Type: IM B3、IM B35、IM B5、IM V1

冷却方式 | Cooling Type: IC411、IC416

变频电机调速范围 | Speed range of Variable Frequency Motor:

2极 | No. of Poles 2: 3 ~ 70Hz(315kW及以下) (315kW and below)
3 ~ 50Hz(355kW及以上) (355kW and above)

4极 | No. of Poles 4: 3 ~ 100Hz(315kW及以下) (315kW and below)
3 ~ 70Hz(355kW及以上) (355kW and above)

6 ~ 10极 | No. of Poles 6 ~ 10: 3 ~ 100Hz



恒转矩调速 | Speed Regulation in Constant Torque: 3 ~ 50Hz

恒功率调速 | Speed Regulation in Constant Power: 50 ~ 70Hz/50 ~ 100Hz

注: 可根据用户要求特殊订制。

Note: Motors can be customized according to customer's requirements.

节能认证 Energy saving certification

中国能效备案标识网 China energy efficiency record label network:

<http://www.energylabel.gov.cn/baggcx/display.htm>



节能对比 Energy-saving

型号 Type	额定功率 (KW) Rated Power	YE3效率 (%) Efficiency	YE4效率 (%) Efficiency	YE5效率 (%) Efficiency	YE4比YE3 年节电 (kWh) Electricity Save	YE4比YE3年节约 运行费用 (元) Cost save	YE5比YE4 年节电 (kWh) Electricity Save	YE5比YE4年节约 运行费用 (元) Cost save
132S1-2	5.5	89.2	90.9	92.6	923	461	889	444
132S2-2	7.5	90.1	91.7	93.3	1162	581	1122	561
160M1-2	11	91.2	92.6	94.0	1459	729	1415	708
160M2-2	15	91.9	93.3	94.5	1959	980	1633	817
160L-2	18.5	92.4	94.7	94.9	2222	1111	1997	999
180M-2	22	92.7	94.0	95.1	2626	1313	2166	1083
200L1-2	30	93.3	94.5	95.5	3266	1633	2659	1330
200L2-2	37	93.7	94.8	95.8	3666	1833	3259	1630
225M-2	45	94.0	95.0	96.0	4031	2016	3947	1974
250M-2	55	94.3	95.3	96.2	4896	2448	4319	2160
280S-2	75	94.7	95.6	96.5	5965	2982	5853	2927
280M-2	90	95.0	95.8	96.6	6329	3164	6224	3112
315S-2	110	95.2	96.0	96.8	7703	3852	7576	3788
315M-2	132	95.4	96.2	96.9	9205	4603	7930	3965
315L1-2	160	95.6	96.3	97.0	9732	4866	9592	4796
315L-2	185	95.7	96.4	97.1	11230	5615	11068	5534
315L2-2	200	95.8	96.5	97.2	12115	6058	11941	5970
355M1-2	220	95.8	96.5	97.2	13327	6663	13135	6567
355M-2	250	95.8	96.5	97.2	15144	7572	14926	7463
355L1-2	280	95.8	96.5	97.2	16961	8481	16717	8358
355L-2	315	95.8	96.5	97.2	19081	9541	18806	9403
3551-2	355	95.8	96.5	97.2	21504	10752	21194	10597
3552-2	400	95.8	96.5	97.2	24230	12115	23881	11941
3553-2	450	95.8	96.5	97.2	27259	13629	26866	13433
4001-2	500	95.8	96.5	97.2	30288	15144	29851	14926
4002-2	560	95.8	96.5	97.2	33922	16961	33434	16717
4003-2	630	95.8	96.5	97.2	38162	19081	37613	18806
4501-2	710	95.8	96.5	97.2	43008	21504	42389	21194
4502-2	800	95.8	96.5	97.2	48460	24230	47762	23881

节能对比 Energy-saving

型号 Type	额定功率 (KW) Rated Power	YE3效率 (%) Efficiency	YE4效率 (%) Efficiency	YE5效率 (%) Efficiency	YE4比YE3 年节电 (kWh) Electricity Save	YE4比YE3年节约 运行费用 (元) Cost save	YE5比YE4 年节电 (kWh) Electricity Save	YE5比YE4年节约 运行费用 (元) Cost save
4503-2	900	95.8	96.5	97.2	54518	27259	53732	26866
4504-2	1000	95.8	96.5	97.2	60575	30288	59703	29851
132S-4	5.5	89.6	91.9	93.4	1229	615	769	384
132M-4	7.5	90.4	92.6	94.0	1577	788	965	483
160M-4	11	91.4	93.3	94.6	1961	980	1296	648
160L-4	15	92.1	93.9	95.1	2498	1249	1613	806
180M-4	18.5	92.6	94.2	95.3	2715	1357	1813	907
180L-4	22	93.0	94.5	95.5	3004	1502	1950	975
200L-4	30	93.6	94.9	95.9	3512	1756	2637	1319
225S-4	37	93.9	95.2	96.1	4305	2152	2912	1456
225M-4	45	94.2	95.4	96.3	4807	2404	3527	1763
250M-4	55	94.6	95.7	96.5	5346	2673	3812	1906
280S-4	75	95.0	96.0	96.7	6579	3289	4524	2262
280M-4	90	95.2	96.1	96.9	7083	3541	6186	3093
315S-4	110	95.4	96.3	97.0	8621	4310	6595	3297
315M-4	132	95.6	96.4	97.1	9167	4583	7897	3949
315L1-4	160	95.8	96.6	97.2	11065	5533	8179	4090
315L-4	185	95.9	96.7	97.3	12768	6384	9438	4719
315L2-4	200	96.0	96.7	97.4	12065	6032	11891	5946
355M1-4	220	96.0	96.7	97.4	13271	6636	13081	6540
355M-4	250	96.0	96.7	97.4	15081	7541	14864	7432
355L2-4	280	96.0	96.7	97.4	16891	8445	16648	8324
355L-4	315	96.0	96.7	97.4	19002	9501	18729	9364
3551-4	355	96.0	96.7	97.4	21415	10708	21107	10554
3552-4	400	96.0	96.7	97.4	24130	12065	23783	11891
3553-4	450	96.0	96.7	97.4	27146	13573	26756	13378
4001-4	500	96.0	96.7	97.4	30162	15081	29728	14864
4002-4	560	96.0	96.7	97.4	33781	16891	33296	16648
4003-4	630	96.0	96.7	97.4	38004	19002	37458	18729
45001-4	710	96.0	96.7	97.4	42830	21415	42214	21107
4502-4	800	96.0	96.7	97.4	48259	24130	47566	23783
4503-4	900	96.0	96.7	97.4	54292	27146	53511	26756
4504-4	1000	96.0	96.7	97.4	60324	30162	59457	29728
132S-6	3	85.6	88.6	90.6	949	475	598	299
132M1-6	4	86.8	89.5	91.4	1112	556	743	372
132M2-6	5.5	88.0	90.5	92.2	1381	691	896	448
160M-6	7.5	89.1	91.3	92.9	1623	811	1132	566
160L-6	11	90.3	92.3	93.7	2112	1056	1425	712



节能对比 Energy-saving

型号 Type	额定功率 (KW) Rated Power	YE3效率 (%) Efficiency	YE4效率 (%) Efficiency	YE5效率 (%) Efficiency	YE4比YE3 年节电 (kWh) Electricity Save	YE4比YE3年节约 运行费用 (元) Cost save	YE5比YE4 年节电 (kWh) Electricity Save	YE5比YE4年节约 运行费用 (元) Cost save
180L-6	15	91.2	92.9	94.3	2408	1204	1918	959
200L1-6	18.5	91.7	93.4	94.6	2938	1469	2010	1005
200L2-6	22	92.2	93.7	94.9	3056	1528	2375	1188
225M-6	30	92.9	94.2	95.3	3565	1783	2941	1470
250M-6	37	93.3	94.5	95.6	4029	2014	3604	1802
280S-6	45	93.7	94.8	95.8	4458	2229	3964	1982
280M-6	55	94.1	95.1	96.0	4917	2458	4338	2169
315S-6	75	94.6	95.4	96.3	5319	2659	5878	2939
315M-6	90	94.9	95.6	96.5	5555	2778	7024	3512
315L1-6	110	95.1	95.8	96.6	6761	3381	7607	3804
315L2-6	132	95.4	96.0	96.8	6918	3459	9091	4545
355M1-6	160	95.6	96.2	96.9	8351	4175	9612	4806
355M-6	185	95.7	96.2	97.0	8038	4019	12688	6344
355M2-6	200	95.8	96.3	97.0	8672	4336	11990	5995
355L1-6	220	95.8	96.3	97.0	9539	4769	13189	6595
355L-6	250	95.8	96.5	97.0	15144	7572	10683	5342
3552-6	315	95.8	96.6	97.0	21785	10892	10758	5379
3553-6	355	95.8	96.6	97.0	24551	12275	12124	6062
4001-6	400	95.8	96.6	97.0	27663	13831	13660	6830
4002-6	450	95.8	96.6	97.0	31121	15560	15368	7684
4003-6	500	95.8	96.6	97.0	34579	17289	17075	8538
4501-6	560	95.8	96.6	97.0	38728	19364	19124	9562
4502-6	630	95.8	96.6	97.0	43569	21785	21515	10758
4503-6	710	95.8	96.6	97.0	49102	24551	24247	12124
4504-6	800	95.8	96.6	97.0	55326	27663	27321	13660

注：1.年运行时间以8000小时测算。

2.电价按0.5元/度测算

Note: 1.The annual operation time is calculated at 8000 hours.

2.The electricity price is 0.5yuan/degree

运行条件 Operating Conditions

环境空气温度 | Ambient Temperature: $-15^{\circ}\text{C} \sim +40^{\circ}\text{C}$

海拔高度 | Altitude: $\leq 1000\text{m}$.

注：当环境温度、海拔与上述规定不同时可按GB/T 755规定进行修正。

Note: When the ambient temperature and altitude are different with the above regulations,

the above conditions can be modified according to GB/T 755 regulations.

湿度 | Humidity: 月平均最高相对湿度为90%。 Average monthly peak relative humidity is

注：电机可根据用户使用环境的要求特殊订制。

Note: Motor can be specially manufactured as per ambient environment of usage.

电机安装型式 Mounting Type

电动机的安装结构型式符合GB/T 997《电机结构及安装型式代号》的规定

The mounting type of this series of motor is accord with regulatuions of GB/T 997 Electric Motor Structure and Mounting Type Code.

结构及安装代号 (IM)	B3	B14	B34	B6	B7	B8	V5	V6
示意图								
机座号	80~450	80~112		80~160				

结构及安装代号 (IM)	B5	V1	V3	B35	V15	V36	V18	V19
示意图								
机座号	80~280	80~355	80~160	80~450	80~160		80~112	

注：对于IM V1安装型式的电机，工频H80~160不带防雨帽，H180~355均带防雨帽；YVF变频系列标配均不带防雨帽。

Note: For motors installation in IM V1, no rain caps for motors in H80-160 of power frequency and rain caps needed for motors in H180-355. YVF series of standard configuration has no rain caps.

轴承寿命 Bearing life

轴承为电机产品中较易磨损的零件，其使用维护状况的好坏与轴承寿命有着密切关系，应当定期维护保养轴承，更换油脂。如不及时更换损坏轴承，易导致电机烧毁。在允许的范围内的负载作用下，电机的轴承设计寿命满足H80~H450：2极电机20000小时；4极、6极、8极、10极电机30000小时（指电机在50Hz下正常运行，并按要求进行正常维护下的寿命）

Bearings are relatively easy-to-wear parts among motor products, and how they are used and maintained is closely related to the life of bearings. Bearings should be regularly maintained and grease should be regularly replaced. If the damaged bearings are not replaced in time, the motor may easily be destroyed. Under the load within the allowable range, the bearing design life of the motor should meet the requirements of H80-H355: 2-pole motor for 20000 hours. 30,000 hours for 4-pole, 6-pole, 8-pole and 10-pole motors (which refers to the life of motor under normal running conditions at 50Hz and under normal maintenance as required).



轴 承 Bearing

电机采用滚动轴承，H80 ~ 450标准配置深沟球轴承或角接触轴承,这些轴承是密封的或可再润滑型的。即：H80 ~ 132采用全封闭免维护轴承；H160 ~ 450采用开启式可再润滑型轴承。

Motors adopt rolling bearing and motors of H80~450 are equipped with deep groove ball bearings or angular contact bearings as per standard. These bearings are sealed or re-lubricated. Motors in H80-132 adopt fully enclosed maintenance-free bearings and motors in H160-450 adopt open & re-lubricated bearings.

电机接线盒 Terminal Box of Motor

电机主电源接线盒的位置默认为顶部，出线口朝右，同时接线盒自身可水平方向旋转180° 安装。接线盒接头采用国家标准设计。根据电动机电流的大小，使用条件，正确选用电缆，进入接线盒中的电缆直径要与密封圈的孔径相符。

The position of the motor main power terminal box is at the top by default. The and box opening is towards the right, and the terminal box can be mounted horizontally by rotating180° . The terminal box connector is designed as per national standards. According to the motor current and the conditions of usage, the cable should be selected correctly. The diameter of the cable entry of the terminal box should match the diameter of the seal ring.

表1 接线盒进线口螺套数量及规格

Table 1 Numbers and Specifications of Screw Sockets at the Inlet of the Terminal Box

机座号 Frame	防护等级 Protection degree	引出线孔的数目 Number of cable grand	接线端子尺寸 Terminal bus	引出口线孔的尺寸 Cable entry size	适用电缆外径 ^a Applicable Cable Outer Diameter ^b
H80 ~ 100	IP55	1	M4	1-M24 × 1.5	φ 10 ~ 14
H112 ~ 132	IP55	2	M5	2-M30 × 2.0	φ 13 ~ 18
H160 ~ 180	IP55	2	M6	2-M36 × 2.0	φ 18 ~ 25
H200 ~ 225	IP55	2	M8	2-M48 × 2.0	φ 22 ~ 36
H250 ~ 280	IP55	2	M10	2-M64 × 2.0	φ 37 ~ 44
H315	IP55	2	M12	2-M64 × 2.0	φ 37 ~ 44
H355	IP55	2	M16	2-M72 × 2.0	φ 51 ~ 57
H355 ^a ~ 400	IP55	3	M16	3-M72 × 2.0	φ 51 ~ 57
H450	IP55	3	M20	3-M72 × 2.0	φ 51 ~ 57

a 系列电动机型谱中机座号为3551、3552、3553时对应的接线盒进线口处螺套数量及规格。

a The corresponding quantity and specification of inserts at cable entry of terminal box, if the frame size of 3551, 3552 and 3553 in series of motor type spectrum.

b 指每个螺套均适用电缆外径。

b Each insert is applicable for cable outer diameter.

接线方法 Wiring

3kW及以下电机（380V）为Y接法，3kW以上电机（380V）为△接法，接线指示图见图1。

Y connection is adapted to motors of 3kw or 3kw below, and △ connection is adapted to motors of 3kw or 3kw above, connection instructions seen as Figure 1



图1.接线指示图
Fig. Wiring Diagram

变频应用 Variable Frequency Application

当电机拖动恒转矩负载且转速低于额定转速运行时，电机需根据实际功率对应选择配置独立驱动风机。

When motor operating with a constant torque load and the speed is lower than rated speed, the motor should select corresponding configured individual drive motor as per actual power.

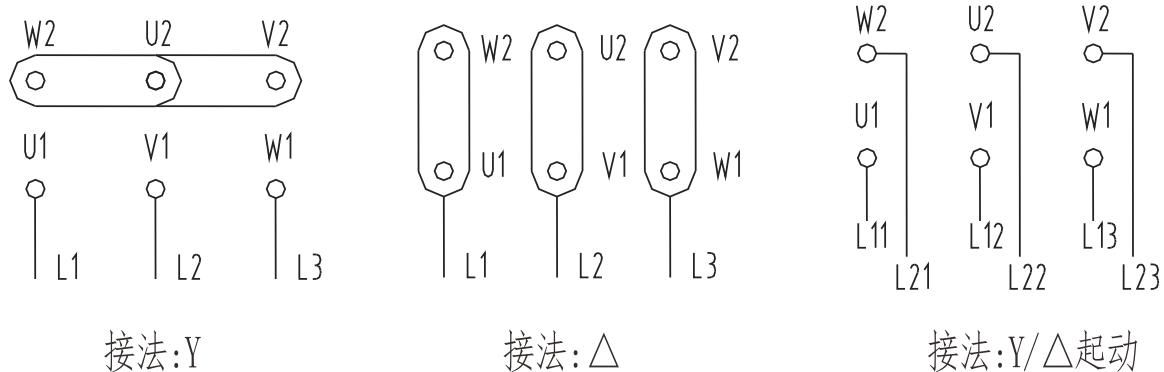
独立风机参数 Technical Date for Separated Fan

对应电机机座号 Motor frame size	电压 V Voltage	频率 Hz Frequency	功率 W Power	电流 A Current	转速 r/min Speed
80	380	50	30	0.09	2300
90	380	50	42	0.13	2800
100	380	50	52	0.13	2800
112	380	50	60	0.13	2730
132	380	50	40	0.1	1300
160	380	50	80	0.2	1350
180	380	50	125	0.3	1350
200	380	50	150	0.6	1350
225	380	50	200	0.6	1350
250	380	50	230	0.6	1350
280	380	50	320	1.1	1250
315	380	50	550	1.5	1400
355	380	50	1100	2.8	1400
3551、3552、3553	380	50	2200	4.8	1410
400	380	50	3000	6.3	1410
450	380	50	4000	8.4	1435

注：表中参数仅供参考，请以电机实际配备风机铭牌参数为准。

Note: The parameters in the table are for reference only, please refer to the parameters of fan nameplate actually equipped with the motor.



电动机型谱 Motor Type Spectrum

机座号 Frame	同步转速 Synchronous Speed (r/min)				
	3000	1500	1000	750	600
	功率 Power (kW)				
80M1	0.75	0.55	0.37	0.18	—
80M2	1.1	0.75	0.55	0.25	—
90S	1.5	1.1	0.75	0.37	—
90L	2.2	1.5	1.1	0.55	—
100L1	3	2.2	1.5	0.75	—
100L2		3		1.1	—
112M	4	4	2.2	1.5	—
132S1	5.5	5.5	3	2.2	—
132S2	7.5				—
132M1	—	7.5	4	3	—
132M2			5.5		—
160M1	11	11	7.5	4	—
160M2	15			5.5	—
160L	18.5	15	11	7.5	—
180M	22	18.5	—	—	—
180L	—	22	15	11	—
200L1	30	30	18.5	15	—
200L2	37		22		—
225S	—	37	—	18.5	—
225M	45	45	30	22	—
250M	55	55	37	30	—
280S	75	75	45	37	—
280M	90	90	55	45	—
280L	110	110	75	55	—



电动机型谱 Motor Type Spectrum

机座号 Frame	同步转速 Synchronous Speed (r/min)				
	3000	1500	1000	750	600
	功率 Power (kW)				
315S	110	110	75	55	45
315M	132	132	90	75	55
315L1	160	160	110	90	75
315L	185	185	—	—	—
315L2	200	200	132	110	90
315L3	220	220	160	132	—
355M1	220	220	160	132	110
355M	250	250	185	—	—
355M2	—	—	200	160	132
355L1	280	280	220	185	—
355L	315	315	250	200	160
355L2	355	355	280	220	185
3551	355	355	—	—	200
3552	400	400	315	250	220
3553	450	450	355	315	—
4001	500	500	400	355	250
4002	560	560	450	400	315
4003	630	630	500	—	355
4501	710	710	560	450	400
4502	800	800	630	500	—
4503	900	900	710	560	450
4504	1000	1000	800	630	500

说明：280L、315L3、355L2为降机座号增容设计。

Description: Frame of 280L, 315L3, 355L2 are capacity-increasing design of frame size decreasing.



三相异步电动机结构剖面示意图

Diagrammatic Cross-section of Three-phase Asynchronous Motor

YE3/YE4/YE5结构剖面示意图 YE3/YE4/YE5 Structural Cross-section Diagram

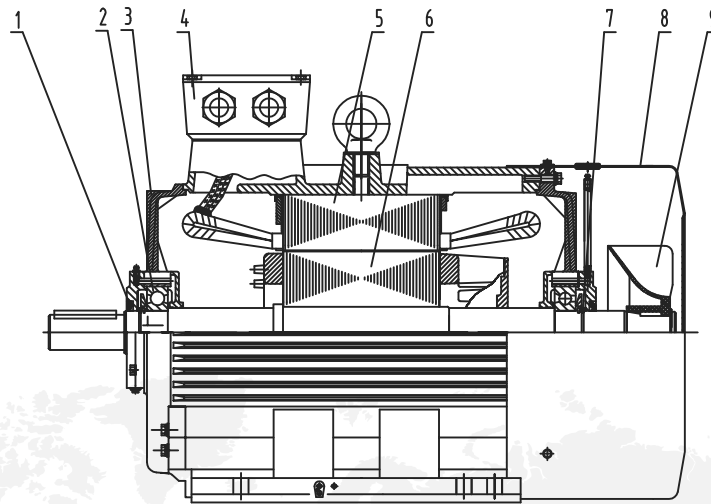

H80 ~ H355

1 端面油封 2 轴承 3 端盖 4 接线盒 5 定子 6 转子 7 波形弹性圈 8 风罩 9 风扇

1 Oil seal (end face) 2 Bearing 3 End cover 4 Terminal box 5 Stator 6 Rotor 7 Waving spring washer 8 Fan cover 9 Fan

注：H80 ~ 132电机为封闭轴承，无轴承内盖和注、排油装置。

Note: Motors of H80 ~ 132 are sealed bearing without bearing inner cap and oil filling and discharging device.

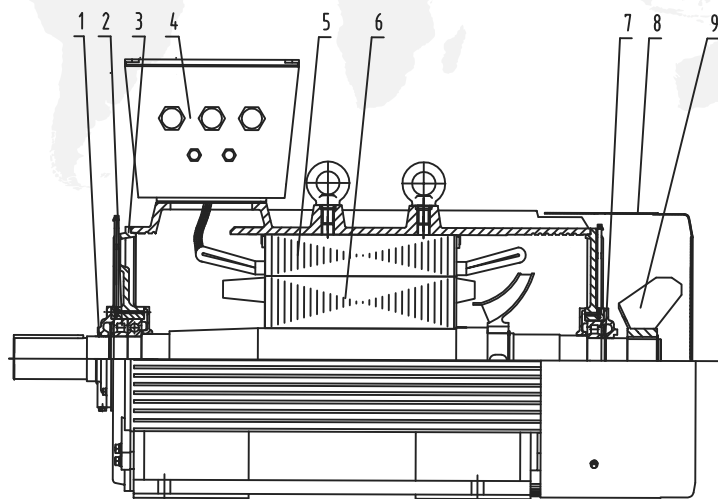

H355^a ~ H450 结构剖面示意图

1 端面油封 2 轴承 3 端盖 4 接线盒 5 定子 6 转子 7 内风扇 8 风罩 9 外风扇

1 Oil seal (end face) 2 Bearing 3 End cover 4 Terminal box 5 Stator 6 Rotor 7 Internal Fan 8 Fan cover 9 External Fan

注：a对应系列电动机型谱中，机座号为3551、3552、3553电机的结构剖面示意图（有内风扇）。

Note: As for a corresponding motor type spectrum, structural cross-section diagram of frame size of 3551, 3552 and 3553. (With internal fan)



YVFE2/YVFE3/YVFE4/YVFE5结构剖面示意图

YVFE2 / YVFE3 / YVFE4 / YVFE5 Structural Cross-section Diagram

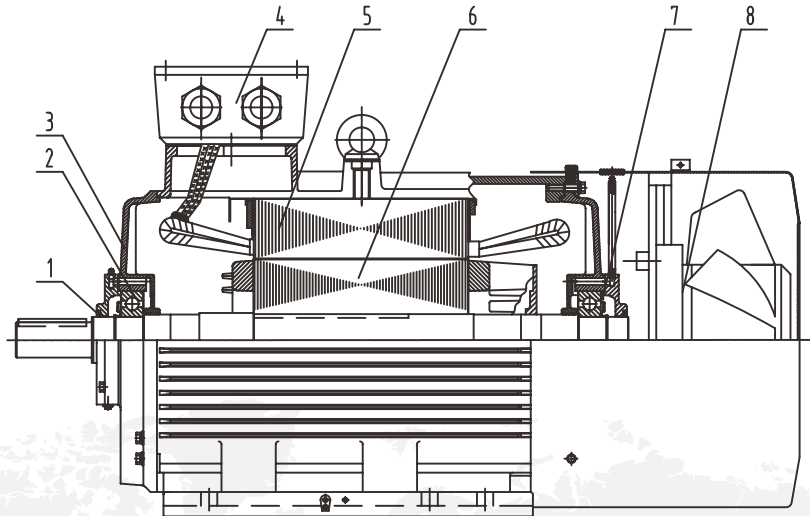

H80 ~ H355

1 端面油封 2 轴承 3 端盖 4 接线盒 5 定子 6 转子 7 波形弹性圈 8 轴流风机

1 Oil seal (end face) 2 Bearing 3 End cover 4 Terminal box 5 Stator 6 Rotor 7 Wavieg slastic ring 8 Axial flow fan

注：H80 ~ 132电机为封闭轴承，无轴承内盖和注、排油装置。

Note: motors of H80 ~ 132 are sealed bearing without bearing inner cap and oil filling and discharging device.

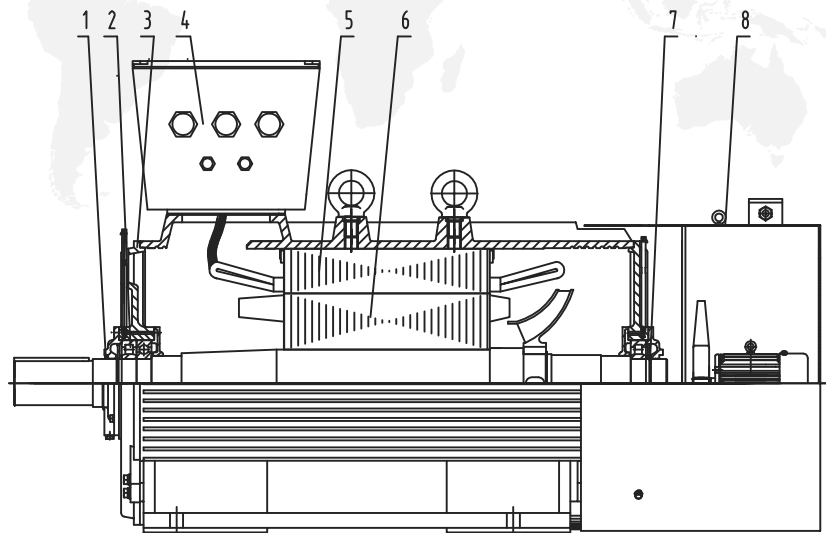

H355^a ~ H450 结构剖面示意图

1 端面油封 2 轴承 3 端盖 4 接线盒 5 定子 6 转子 7 内风扇 8 风机

1 Oil seal (end face) 2 Bearing 3 End cover 4 Terminal box 5 Stator 6 Rotor 7 Internal Fan 8 Blower

注：a对应系列电动机型谱中，机座号为3551、3552、3553电机的结构剖面示意图（有内风扇）

Note: As for a corresponding motor type spectrum, structural cross-section diagram of frame size of 3551, 3552 and 3553. (With internal fan)



系列电动机技术数据 Series Motor Technical Data

YE3系列三相异步电机

YE3 Series Three-phase Asynchronous Motor

本系列电动机是我公司自主研发的高效节能三相异步电动机，冷却方式为：IC411，电机性能满足GB/T 28575《YE3系列（IP55）三相异步电动机技术条件（机座号63~355）》或JB/T 10868《YE3系列（IP55）三相异步电动机技术条件（机座号355~450）》，效率值符合GB 18613-2020中3级能效标准，并与国际标准IEC 60034-30《单速三相笼型感应电动机能效分级》中的IE3一致。本系列产品能够完全取代Y、YGM、YGM2、YE2系列低压三相异步电动机。

YE3系列三相异步电动机具有性能优良、高效、节能，温升裕度大，寿命长，性能好，振动小，启动性能优良，外形美观，可靠性能高的优点。常用于驱动水泵、风机、压缩机、传送机和其他传动机械被应用在节能环保改造、国家水利等项目。

This series of motor is high efficiency and energy-saving three phase asynchronous motor, which is independently developed by our company. The coolant mode is IC411. Motor performance meets GB/T 28575 Specifications for YE3-series (IP55) High Efficiency Three Phase Induction Motor (Frame size 63-355) or JB/T 10868"YE3 Series (IP55) Three Phase Asynchronous Motor Technical Conditions (Frame Size 355-450). Its efficiency value complies with the grade 3 energy efficiency standard in GB 18613-2020 and is consistent with the IE3 in the international standard IEC 60034-30 Energy Efficiency Class of Single-speed Three-phase Cage Induction Motors. This series of products can completely replace the obsolete products of low-voltage three-phase asynchronous motors, such as Y, YGM, YGM2 and YE2-series.

This series of motors have the advantages of excellent performance, high efficiency, energy saving, large temperature rise margin, long life, low vibration, excellent starting performance, nice appearance and high reliability, which are commonly used to drive water pumps, fans, compressors, conveyors and other transmission machinery in energy conservation and environmental protection transformation projects, national water conservancy projects, etc.

YE3

电动机型号说明 Motor Type Description

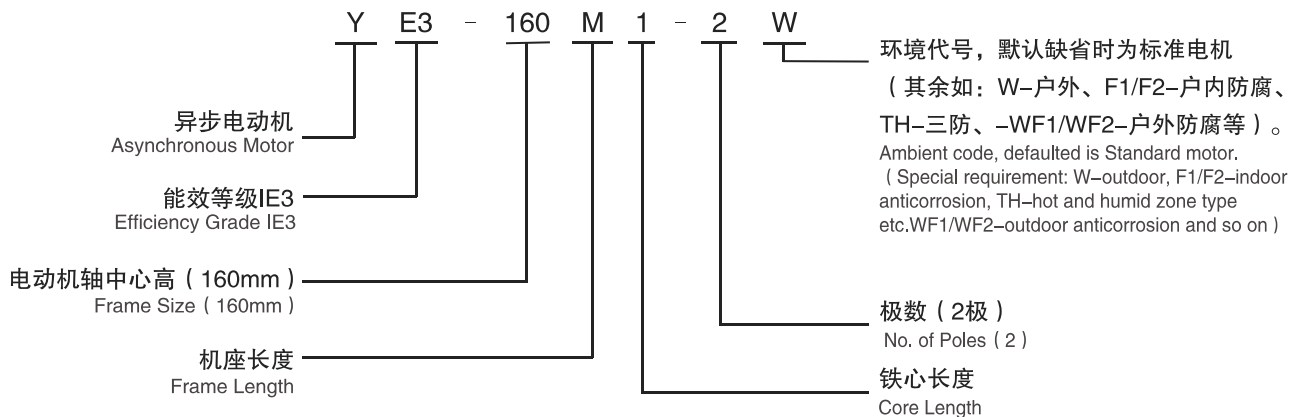

电气性能参数表YE3 50Hz Electrical Property Parameters Table YE3 50Hz

型号 Type	额定功率 kW Rated Power	额定电压 V Rated Voltage	额定电流 A Rated Current	额定转速 r/min Rated Speed	效率 % Efficiency	功率因数 Cos φ Power Factor	堵转转矩 Locked Torque	堵转电流 Locked Current	最大转矩 Max. Torque	额定 转矩 N · m Rated Torque	空载 噪声 dB (A) No-Load Noise	质量 Kg Weight
							额定转矩 Rated Torque	额定电流 Rated Current				
同步转速Synchronous Speed 3000r/min												
YE3-80M1-2	0.75	380	1.7	2880	80.7	0.82	2.3	7.0	2.3	2.4	62	18
YE3-80M2-2	1.1	380	2.4	2880	82.7	0.83	2.2	7.6	2.3	3.5	62	19
YE3-90S-2	1.5	380	3.2	2890	84.2	0.84	2.2	7.9	2.3	4.8	67	23
YE3-90L-2	2.2	380	4.6	2890	85.9	0.85	2.2	7.9	2.3	7.0	67	24
YE3-100L-2	3	380	6.0	2910	87.1	0.87	2.2	8.5	2.3	9.6	74	34
YE3-112M-2	4	380	7.8	2910	88.1	0.88	2.2	8.5	2.3	12.7	77	44
YE3-132S1-2	5.5	380	10.6	2945	89.2	0.88	2.0	8.5	2.3	17.5	79	58
YE3-132S2-2	7.5	380	14.4	2940	90.1	0.88	2.0	8.5	2.3	23.9	79	63
YE3-160M1-2	11	380	20.6	2950	91.2	0.89	2.0	8.5	2.3	35.0	81	124
YE3-160M2-2	15	380	27.9	2950	91.9	0.89	2.0	8.5	2.3	47.8	81	135
YE3-160L-2	18.5	380	34.2	2950	92.4	0.89	2.0	8.5	2.3	58.9	81	150
YE3-180M-2	22	380	40.5	2960	92.7	0.89	2.0	8.5	2.3	70.0	83	161
YE3-200L1-2	30	380	54.9	2970	93.3	0.89	2.0	8.5	2.3	95.5	84	230
YE3-200L2-2	37	380	67.4	2975	93.7	0.89	2.0	8.5	2.3	118	84	256
YE3-225M-2	45	380	80.8	2975	94.0	0.90	2.0	8.0	2.3	143	86	317
YE3-250M-2	55	380	98.5	2970	94.3	0.90	2.0	8.0	2.3	175	89	400
YE3-280S-2	75	380	134	2980	94.7	0.90	1.8	7.5	2.3	239	91	460
YE3-280M-2	90	380	160	2980	95.0	0.90	1.8	7.5	2.3	287	91	530
YE3-280L-2	110	380	195	2980	95.2	0.90	1.8	7.5	2.3	350	92	656
YE3-315S-2	110	380	195	2975	95.2	0.90	1.8	7.5	2.3	350	92	875
YE3-315M-2	132	380	234	2975	95.4	0.90	1.8	7.5	2.3	420	92	965
YE3-315L1-2	160	380	279	2975	95.6	0.91	1.8	7.5	2.3	509	92	1033
YE3-315L-2	185	380	323	2975	95.7	0.91	1.8	7.5	2.3	589	92	1085
YE3-315L2-2	200	380	349	2975	95.8	0.91	1.8	7.5	2.2	637	92	1085
YE3-315L3-2	220	380	383	2975	95.8	0.91	1.6	7.5	2.2	700	100	1310
YE3-355M1-2	220	380	383	2980	95.8	0.91	1.6	7.5	2.2	700	100	1600
YE3-355M-2	250	380	436	2980	95.8	0.91	1.6	7.5	2.2	796	100	1670
YE3-355L1-2	280	380	488	2980	95.8	0.91	1.6	7.5	2.2	891	100	1790
YE3-355L-2	315	380	549	2980	95.8	0.91	1.6	7.5	2.2	1003	100	1820
YE3-355L2-2	355	380	619	2980	95.8	0.91	1.6	7.5	2.2	1130	100	1860
YE3-3551-2	355	380	626	2985	95.8	0.90	0.9	8.6	1.8	1130	101	2625
YE3-3552-2	400	380	705	2985	95.8	0.90	0.9	8.6	1.8	1273	101	2690
YE3-3553-2	450	380	793	2985	95.8	0.90	0.8	8.6	1.8	1433	105	2735
YE3-4001-2	500	380	881	2985	95.8	0.90	0.8	8.6	1.8	1592	105	3280
YE3-4002-2	560	380	976	2985	95.8	0.91	0.8	8.7	1.8	1783	106	3540
YE3-4003-2	630	660	632	2985	95.8	0.91	0.8	8.7	1.8	2006	106	3620
YE3-4501-2	710	660	712	2985	95.8	0.91	0.6	7.9	1.8	2260	106	4410
YE3-4502-2	800	660	803	2985	95.8	0.91	0.6	7.9	1.8	2547	106	4775
YE3-4503-2	900	660	903	2985	95.8	0.91	0.6	7.9	1.8	2865	106	5142
YE3-4504-2	1000	660	993	2985	95.8	0.92	0.6	8.0	1.8	3183	106	5513
同步转速Synchronous Speed 1500r/min												
YE3-80M1-4	0.55	380	1.4	1435	80.8	0.75	2.4	6.6	2.3	3.5	56	16
YE3-80M2-4	0.75	380	1.8	1435	82.5	0.75	2.3	6.6	2.3	4.8	56	17
YE3-90S-4	1.1	380	2.6	1440	84.1	0.76	2.3	6.8	2.3	7.0	59	23
YE3-90L-4	1.5	380	3.5	1440	85.3	0.77	2.3	7.0	2.3	9.6	59	25
YE3-100L1-4	2.2	380	4.8	1450	86.7	0.81	2.3	7.6	2.3	14.0	64	27



电气性能参数表YE3 50Hz Electrical Property Parameters Table YE3 50Hz

型号 Type	额定功率 kW Rated Power	额定电压 V Rated Voltage	额定电流 A Rated Current	额定转速 r/min Rated Speed	效率 % Efficiency	功率因数 Cos φ Power Factor	堵转转矩 Locked Torque	堵转电流 Locked Current	最大转矩 Max. Torque	额定 转矩 N · m Rated Torque	空载 噪声 dB (A) No-Load Noise	质量 Kg Weight
							额定转矩 Rated Torque	额定电流 Rated Current				
同步转速Synchronous Speed 1500r/min												
YE3-100L2-4	3	380	6.3	1450	87.7	0.82	2.3	7.6	2.3	19.1	64	30
YE3-112M-4	4	380	8.4	1450	88.6	0.82	2.2	7.8	2.3	25.5	65	35
YE3-132S-4	5.5	380	11.2	1470	89.6	0.83	2.0	7.9	2.3	35.0	71	65
YE3-132M-4	7.5	380	15.0	1470	90.4	0.84	2.0	7.5	2.3	47.8	71	78
YE3-160M-4	11	380	21.5	1475	91.4	0.85	2.2	7.7	2.3	70.0	73	135
YE3-160L-4	15	380	28.8	1475	92.1	0.86	2.2	7.8	2.3	95.5	73	147
YE3-180M-4	18.5	380	35.3	1480	92.6	0.86	2.0	7.8	2.3	118	76	172
YE3-180L-4	22	380	41.8	1480	93.0	0.86	2.0	7.8	2.3	140	76	198
YE3-200L-4	30	380	56.6	1475	93.6	0.86	2.0	7.3	2.3	191	76	251
YE3-225S-4	37	380	69.6	1485	93.9	0.86	2.0	7.4	2.3	236	78	305
YE3-225M-4	45	380	84.4	1485	94.2	0.86	2.0	7.4	2.3	287	78	335
YE3-250M-4	55	380	103	1480	94.6	0.86	2.2	7.4	2.3	350	79	420
YE3-280S-4	75	380	136	1490	95.0	0.88	2.0	6.9	2.3	478	80	510
YE3-280M-4	90	380	163	1490	95.2	0.88	2.0	6.9	2.3	573	80	570
YE3-280L-4	110	380	195	1490	95.4	0.90	1.8	7.5	2.3	700	80	650
YE3-315S-4	110	380	197	1485	95.4	0.89	2.0	7.0	2.2	700	88	870
YE3-315M-4	132	380	236	1485	95.6	0.89	2.0	7.0	2.2	840	88	960
YE3-315L1-4	160	380	285	1485	95.8	0.89	2.0	7.1	2.2	1019	88	1140
YE3-315L-4	185	380	326	1485	95.9	0.90	2.0	7.1	2.2	1178	88	1144
YE3-315L2-4	200	380	352	1485	96.0	0.90	2.0	7.1	2.2	1273	88	1144
YE3-315L3-4	220	380	387	1485	96.0	0.90	2.0	7.1	2.2	1401	88	1310
YE3-355M1-4	220	380	387	1490	96.0	0.90	2.0	7.1	2.2	1401	95	1630
YE3-355M-4	250	380	440	1490	96.0	0.90	2.0	7.1	2.2	1592	95	1680
YE3-355L1-4	280	380	492	1490	96.0	0.90	2.0	7.1	2.2	1783	95	1750
YE3-355L-4	315	380	554	1490	96.0	0.90	2.0	7.1	2.2	2006	95	1820
YE3-355L2-4	355	380	624	1490	96.0	0.90	2.0	7.1	2.2	2260	95	1860
YE3-355L-4	355	380	638	1490	96.0	0.88	0.9	8.4	1.8	2260	99	2840
YE3-3552-4	400	380	719	1490	96.0	0.88	0.9	8.4	1.8	2547	99	2970
YE3-3553-4	450	380	809	1490	96.0	0.88	0.8	8.4	1.8	2865	102	3000
YE3-4001-4	500	380	899	1490	96.0	0.88	0.8	8.4	1.8	3183	102	3455
YE3-4002-4	560	380	996	1490	96.0	0.89	0.8	8.5	1.8	3565	105	3550
YE3-4003-4	630	660	645	1490	96.0	0.89	0.8	8.5	1.8	4011	105	3670
YE3-4501-4	710	660	727	1490	96.0	0.89	0.6	7.8	1.8	4520	105	4750
YE3-4502-4	800	660	810	1490	96.0	0.90	0.6	7.9	1.8	5093	105	5065
YE3-4503-4	900	660	911	1490	96.0	0.90	0.6	7.9	1.8	5730	105	5400
YE3-4504-4	1000	660	1012	1490	96.0	0.90	0.6	7.9	1.8	6367	105	5725
同步转速Synchronous Speed 1000r/min												
YE3-80M1-6	0.37	380	1.1	928	73.5	0.70	1.9	6.0	2.0	3.5	54	26
YE3-80M2-6	0.55	380	1.5	928	77.2	0.72	1.9	6.0	2.1	5.3	54	27
YE3-90S-6	0.75	380	2.0	950	78.9	0.71	2.0	6.0	2.1	7.2	57	30
YE3-90L-6	1.1	380	2.8	950	81.0	0.73	2.0	6.0	2.1	10.5	57	32
YE3-100L1-6	1.5	380	3.8	955	82.5	0.73	2.0	6.5	2.1	14.3	61	40
YE3-112M-6	2.2	380	5.4	955	84.3	0.74	2.0	6.6	2.1	21.0	65	45
YE3-132S-6	3	380	7.2	970	85.6	0.74	2.0	6.8	2.1	28.7	69	57
YE3-132M1-6	4	380	9.5	970	86.8	0.74	2.0	6.8	2.1	38.2	69	68
YE3-132M2-6	5.5	380	12.7	970	88.0	0.75	2.0	7.0	2.1	52.5	69	78

YE3

电气性能参数表YE3 50Hz Electrical Property Parameters Table YE3 50Hz

型号 Type	额定功率 kW Rated Power	额定电压 V Rated Voltage	额定电流 A Rated Current	额定转速 r/min Rated Speed	效率 % Efficiency	功率因数 Cos φ Power Factor	堵转转矩 Locked Torque	堵转电流 Locked Current	最大转矩 Max. Torque	额定 转矩 N · m Rated Torque	空载 噪声 dB (A) No-Load Noise	质量 Kg Weight
							额定转矩 Rated Torque	额定电流 Rated Current	额定转矩 Rated Torque			
同步转速Synchronous Speed 1000r/min												
YE3-160M-6	7.5	380	16.2	980	89.1	0.79	2.0	7.0	2.1	71.6	73	122
YE3-160L-6	11	380	23.1	980	90.3	0.80	2.0	7.2	2.1	105	73	149
YE3-180L-6	15	380	30.9	980	91.2	0.81	2.0	7.3	2.1	143	73	181
YE3-200L1-6	18.5	380	37.8	985	91.7	0.81	2.0	7.3	2.1	177	73	229
YE3-200L2-6	22	380	44.8	985	92.2	0.81	2.0	7.4	2.1	210	73	245
YE3-225M-6	30	380	59.1	990	92.9	0.83	2.0	6.9	2.1	287	74	300
YE3-250M-6	37	380	71.7	990	93.3	0.84	2.0	7.1	2.1	353	76	362
YE3-280S-6	45	380	85.8	990	93.7	0.85	2.0	7.3	2.0	430	78	498
YE3-280M-6	55	380	103	990	94.1	0.86	2.0	7.3	2.0	525	78	577
YE3-280L-6	75	380	143	990	94.6	0.84	2.0	6.6	2.1	716	78	710
YE3-315S-6	75	380	143	990	94.6	0.84	2.0	6.6	2.0	716	83	810
YE3-315M-6	90	380	170	990	94.9	0.85	2.0	6.7	2.0	860	83	900
YE3-315L1-6	110	380	207	990	95.1	0.85	2.0	6.7	2.0	1051	83	1060
YE3-315L2-6	132	380	244	990	95.4	0.86	2.0	6.8	2.0	1261	83	1210
YE3-315L3-6	160	380	296	990	95.6	0.86	1.8	6.8	2.0	1528	83	1310
YE3-355M1-6	160	380	296	990	95.6	0.86	1.8	6.8	2.0	1528	85	1630
YE3-355M-6	185	380	342	990	95.7	0.86	1.8	6.8	2.0	1767	85	1680
YE3-355M2-6	200	380	365	990	95.8	0.87	1.8	6.8	2.0	1910	85	1750
YE3-355L1-6	220	380	401	990	95.8	0.87	1.8	6.8	2.0	2101	85	1830
YE3-355L-6	250	380	456	990	95.8	0.87	1.8	6.8	2.0	2388	85	1920
YE3-355L2-6	280	380	510	990	95.8	0.87	1.8	6.8	2.0	2674	85	1960
YE3-3552-6	315	380	609	995	95.8	0.82	0.9	7.8	1.8	3008	95	2830
YE3-3553-6	355	380	687	995	95.8	0.82	0.9	7.8	1.8	3390	95	2940
YE3-4001-6	400	380	764	995	95.8	0.83	0.9	7.9	1.8	3820	95	3340
YE3-4002-6	450	380	860	995	95.8	0.83	0.8	7.9	1.8	4298	99	3500
YE3-4003-6	500	660	550	995	95.8	0.83	0.8	7.9	1.8	4775	99	3700
YE3-4501-6	560	660	609	995	95.8	0.84	0.8	8.0	1.8	5348	102	4692
YE3-4502-6	630	660	685	995	95.8	0.84	0.8	8.0	1.8	6017	102	5013
YE3-4503-6	710	660	772	995	95.8	0.84	0.6	7.3	1.8	6781	102	5223
YE3-4504-6	800	660	870	995	95.8	0.84	0.6	7.3	1.8	7640	102	5433
同步转速Synchronous Speed 750r/min												
YE3-80M1-8	0.18	380	0.8	650	58.7	0.61	1.8	5.2	1.9	2.3	52	27
YE3-80M2-8	0.25	380	1.0	650	64.1	0.61	1.8	5.7	1.9	3.2	52	32
YE3-90S-8	0.37	380	1.3	670	69.3	0.61	1.8	6.2	1.9	4.7	56	36
YE3-90L-8	0.55	380	1.9	670	73.0	0.61	1.8	5.9	2.0	7.0	56	42
YE3-100L1-8	0.75	380	2.3	690	75.0	0.67	1.8	6.2	2.0	9.6	59	45
YE3-100L2-8	1.1	380	3.1	690	77.7	0.69	1.8	6.2	2.0	14.0	59	46
YE3-112M-8	1.5	380	4.1	690	78.7	0.70	1.8	6.7	2.0	19.1	61	47
YE3-132S-8	2.2	380	5.7	710	81.9	0.71	1.8	6.7	2.0	28.0	64	56
YE3-132M-8	3	380	7.5	710	83.5	0.73	1.8	6.9	2.0	38.2	64	69
YE3-160M1-8	4	380	9.8	720	84.8	0.73	1.9	6.9	2.0	50.9	68	118
YE3-160M2-8	5.5	380	13.1	720	86.2	0.74	1.9	6.9	2.0	70.0	68	133
YE3-160L-8	7.5	380	17.4	720	87.3	0.75	1.9	6.6	2.0	95.5	68	140
YE3-180L-8	11	380	25.2	730	88.6	0.75	2.0	6.6	2.0	140	70	169
YE3-200L-8	15	380	33.5	730	89.6	0.76	2.0	6.8	2.0	191	70	218
YE3-225S-8	18.5	380	41.0	730	90.1	0.76	1.9	6.8	2.0	236	73	259



电气性能参数表YE3 50Hz Electrical Property Parameters Table YE3 50Hz

型号 Type	额定功率 kW	额定电压 V	额定电流 A	额定转速 r/min	效率 %	功率因数 Cos φ	堵转转矩 Locked Torque	堵转电流 Locked Current	最大转矩 Max. Torque	额定 转矩 N · m	空载 噪声 dB (A) No-Load Noise	质量 Kg
	Rated Power	Rated Voltage	Rated Current	Rated Speed	Efficiency	Power Factor	额定转矩 Rated Torque	额定电流 Rated Current	额定转矩 Rated Torque	Rated Torque		
同步转速Synchronous Speed 750 r/min												
YE3-225M-8	22	380	47.3	730	90.6	0.78	1.9	7.0	2.0	280	73	291
YE3-250M-8	30	380	63.2	730	91.3	0.79	1.9	6.7	2.0	382	73	385
YE3-280S-8	37	380	77.5	740	91.8	0.79	1.9	6.7	2.0	471	76	457
YE3-280M-8	45	380	93.9	740	92.2	0.79	1.9	6.7	2.0	573	76	522
YE3-280L-8	55	380	112	740	92.5	0.81	1.8	6.8	2.0	700	76	630
YE3-315S-8	55	380	112	740	92.5	0.81	1.8	6.8	2.0	700	82	1000
YE3-315M-8	75	380	151	740	93.1	0.81	1.8	6.3	2.0	955	82	1005
YE3-315L1-8	90	380	179	740	93.4	0.82	1.8	6.4	2.0	1146	82	1080
YE3-315L2-8	110	380	218	740	93.7	0.82	1.8	6.4	2.0	1401	82	1160
YE3-315L3-8	132	380	260	740	94.0	0.82	1.8	6.4	2.0	1681	82	1345
YE3-355M1-8	132	380	260	740	94.0	0.82	1.8	6.4	2.0	1681	89	1580
YE3-355M2-8	160	380	314	740	94.3	0.82	1.8	6.4	2.0	2037	89	1690
YE3-355L1-8	185	380	362	740	94.5	0.82	1.8	6.4	2.0	2356	89	1840
YE3-355L-8	200	380	387	740	94.6	0.83	1.8	6.4	2.0	2547	89	1940
YE3-355L2-8	220	380	426	740	94.6	0.83	1.8	6.4	2.0	2801	89	1980
YE3-3552-8	250	380	502	740	94.6	0.80	1.1	7.5	1.8	3183	92	2800
YE3-3553-8	315	380	632	740	94.6	0.80	0.9	7.5	1.8	4011	92	2990
YE3-4001-8	355	380	713	745	94.6	0.80	0.9	7.5	1.8	4520	92	3570
YE3-4002-8	400	660	462	745	94.6	0.80	0.9	7.5	1.8	5093	92	3765
YE3-4501-8	450	660	514	745	94.6	0.81	0.8	7.6	1.8	5730	96	4671
YE3-4502-8	500	660	571	745	94.6	0.81	0.8	7.6	1.8	6367	96	4930
YE3-4503-8	560	660	639	745	94.6	0.81	0.8	7.6	1.8	7131	99	5227
YE3-4504-8	630	660	719	745	94.6	0.81	0.8	7.6	1.8	8022	99	5527
同步转速Synchronous Speed 600 r/min												
YE3-315S-10	45	380	99.1	590	92.0	0.75	1.5	6.2	2.0	716.2	82	785
YE3-315M-10	55	380	121	590	92.0	0.75	1.5	6.2	2.0	875.4	82	925
YE3-315L1-10	75	380	162	590	92.8	0.76	1.5	5.8	2.0	1194	82	1030
YE3-315L2-10	90	380	191	590	93.0	0.77	1.5	5.9	2.0	1433	82	1080
YE3-355M-10	90	380	191	590	93.0	0.77	1.5	5.9	2.0	1433	90	1490
YE3-355M1-10	110	380	230	590	93.3	0.78	1.3	6.0	2.0	1750	90	1630
YE3-355M2-10	132	380	274	590	93.8	0.78	1.3	6.1	2.0	2101	90	1750
YE3-355L-10	160	380	332	590	93.8	0.78	1.3	6.1	2.0	2547	90	1910
YE3-355L2-10	185	380	384	590	93.8	0.78	1.3	6.1	2.0	2945	90	1950
YE3-3552-10	200	380	437	590	93.9	0.74	1.1	6.9	1.8	3183	92	2870
YE3-3553-10	250	380	547	590	93.9	0.74	1.1	6.9	1.8	3979	92	3000
YE3-4002-10	315	380	658	595	94.4	0.77	1.1	7.0	1.8	5014	92	3625
YE3-4003-10	355	380	742	595	94.4	0.77	0.9	7.0	1.8	5650	92	3870
YE3-4502-10	400	380	835	595	94.5	0.77	0.9	7.0	1.8	6367	96	4840
YE3-4503-10	450	380	940	595	94.5	0.77	0.8	7.0	1.8	7163	96	5170
YE3-4504-10	500	380	1043	595	94.6	0.77	0.8	7.0	1.8	7958	99	5500

注：1 表中电动机质量为理论计算值，与实际值有一定偏差，仅供参考，电动机重量以实际称重为准（详见铭牌信息）。

Note: 1. The motor quality in the table is calculated theoretically and deviates from the actual value. It is for reference only. The actual weighing of the motor is taken as the criterion (Please see as per details of nameplate).

YE3



(IM B3) 机座带底脚，端盖上无凸缘的电动机 Frame with foot and without flange on end shield

单位unit: mm

机座号 Frame	极数 Number of Poles	安装尺寸及公差 Mounting Dimension and Tolerances									外形尺寸 Overall Dimensios				
		A	B	C	D	E	F	G ^a	H	K ^b	AB	AC	AD	HD	L
80M	2/4/6/8	125	100	50 ± 1.5	19 ^{+0.009} _{-0.004}	40 ± 0.31	6 ⁰ _{-0.03}	15.5 ⁰ _{-0.1}	80 ⁰ _{-0.5}	10 ^{+0.36} ₀	165	175	145	220	305
90S	2/4/6/8	140	100	56 ± 1.5	24 ^{+0.009} _{-0.004}	50 ± 0.31	8 ⁰ _{-0.036}	20 ⁰ _{-0.2}	90 ⁰ _{-0.5}	10 ^{+0.36} ₀	180	205	170	265	360
90L	2/4/6/8	140	125	56 ± 1.5	24 ^{+0.009} _{-0.004}	50 ± 0.31	8 ⁰ _{-0.036}	20 ⁰ _{-0.2}	90 ⁰ _{-0.5}	10 ^{+0.36} ₀	180	205	170	265	390
100L	2/4/6/8	160	140	63 ± 2.0	28 ^{+0.009} _{-0.004}	60 ± 0.37	8 ⁰ _{-0.036}	24 ⁰ _{-0.2}	100 ⁰ _{-0.5}	12 ^{+0.43} ₀	205	215	180	270	435
112M	2/4/6/8	190	140	70 ± 2.0	28 ^{+0.009} _{-0.004}	60 ± 0.37	8 ⁰ _{-0.036}	24 ⁰ _{-0.2}	112 ⁰ _{-0.5}	12 ^{+0.43} ₀	230	255	200	310	440
132S	2/4/6/8	216	140	89 ± 2.0	38 ^{+0.018} _{+0.002}	80 ± 0.37	10 ⁰ _{-0.036}	33 ⁰ _{-0.2}	132 ⁰ _{-0.5}	12 ^{+0.43} ₀	270	310	235	365	530
132M	4/6/8	216	178	89 ± 2.0	38 ^{+0.018} _{+0.002}	80 ± 0.37	10 ⁰ _{-0.036}	33 ⁰ _{-0.2}	132 ⁰ _{-0.5}	12 ^{+0.43} ₀	270	310	235	365	560
160M	2/4/6/8	254	210	108 ± 3.0	42 ^{+0.018} _{+0.002}	110 ± 0.43	12 ⁰ _{-0.043}	37 ⁰ _{-0.2}	160 ⁰ _{-0.5}	14.5 ^{+0.43} ₀	320	340	260	425	670
160L	2/4/6/8	254	254	108 ± 3.0	42 ^{+0.018} _{+0.002}	110 ± 0.43	12 ⁰ _{-0.043}	37 ⁰ _{-0.2}	160 ⁰ _{-0.5}	14.5 ^{+0.43} ₀	320	340	260	425	710
180M	2/4	279	241	121 ± 3.0	48 ^{+0.018} _{+0.002}	110 ± 0.43	14 ⁰ _{-0.043}	42.5 ⁰ _{-0.2}	180 ⁰ _{-1.0}	14.5 ^{+0.43} ₀	355	390	280	460	740
180L	4/6/8	279	279	121 ± 3.0	48 ^{+0.018} _{+0.002}	110 ± 0.43	14 ⁰ _{-0.043}	42.5 ⁰ _{-0.2}	180 ⁰ _{-0.5}	14.5 ^{+0.43} ₀	355	390	280	460	780
200L	2/4/6/8	318	305	133 ± 3.0	55 ^{+0.030} _{+0.011}	110 ± 0.43	16 ⁰ _{-0.043}	49 ⁰ _{-0.2}	200 ⁰ _{-0.5}	18.5 ^{+0.52} ₀	395	445	320	520	880
225S	4/8	356	286	149 ± 4.0	60 ^{+0.030} _{+0.011}	140 ± 0.50	18 ⁰ _{-0.043}	53 ⁰ _{-0.2}	225 ⁰ _{-0.5}	18.5 ^{+0.52} ₀	435	470	335	560	890
225M	2	356	311	149 ± 4.0	55 ^{+0.030} _{+0.011}	110 ± 0.43	16 ⁰ _{-0.043}	49 ⁰ _{-0.2}	225 ⁰ _{-0.5}	18.5 ^{+0.52} ₀	435	470	335	560	900
	4/6/8	356	311	149 ± 4.0	60 ^{+0.030} _{+0.011}	140 ± 0.50	18 ⁰ _{-0.043}	53 ⁰ _{-0.2}	225 ⁰ _{-0.5}	18.5 ^{+0.52} ₀	435	470	335	560	930
250M	2	406	349	168 ± 4.0	60 ^{+0.030} _{+0.011}	140 ± 0.50	18 ⁰ _{-0.043}	53 ⁰ _{-0.2}	250 ⁰ _{-0.5}	24 ^{+0.52} ₀	490	550	390	635	990
	4/6/8	406	349	168 ± 4.0	65 ^{+0.030} _{+0.011}	140 ± 0.50	18 ⁰ _{-0.043}	58 ⁰ _{-0.2}	250 ⁰ _{-0.5}	24 ^{+0.52} ₀	490	550	390	635	990
280S	2	457	368	190 ± 4.0	65 ^{+0.030} _{+0.011}	140 ± 0.50	18 ⁰ _{-0.043}	58 ⁰ _{-0.2}	280 ⁰ _{-1.0}	24 ^{+0.52} ₀	550	630	435	705	990
	4/6/8	457	368	190 ± 4.0	75 ^{+0.030} _{+0.011}	140 ± 0.50	20 ⁰ _{-0.052}	67.5 ⁰ _{-0.2}	280 ⁰ _{-1.0}	24 ^{+0.52} ₀	550	630	435	705	990
280M	2	457	419	190 ± 4.0	65 ^{+0.030} _{+0.011}	140 ± 0.50	18 ⁰ _{-0.43}	58 ⁰ _{-0.2}	280 ⁰ _{-1.0}	24 ^{+0.52} ₀	550	630	435	705	1040
	4/6/8	457	419	190 ± 4.0	75 ^{+0.030} _{+0.011}	140 ± 0.50	20 ⁰ _{-0.052}	67.5 ⁰ _{-0.2}	280 ⁰ _{-1.0}	24 ^{+0.52} ₀	550	630	435	705	1040
280L	2	457	419	190 ± 4.0	65 ^{+0.030} _{+0.011}	140 ± 0.50	18 ⁰ _{-0.043}	58 ⁰ _{-0.2}	280 ⁰ _{-1.0}	24 ^{+0.52} ₀	550	630	435	705	1080
	4/6/8	457	419	190 ± 4.0	75 ^{+0.030} _{+0.011}	140 ± 0.50	20 ⁰ _{-0.052}	67.5 ⁰ _{-0.2}	280 ⁰ _{-1.0}	24 ^{+0.52} ₀	550	630	435	705	1080
315S	2	508	406	216 ± 4.0	65 ^{+0.030} _{+0.011}	140 ± 0.50	18 ⁰ _{-0.043}	58 ⁰ _{-0.2}	315 ⁰ _{-1.0}	28 ^{+0.52} ₀	635	645	530	845	1220
	4/6/8/10	508	406	216 ± 4.0	80 ^{+0.030} _{+0.011}	170 ± 0.50	22 ⁰ _{-0.052}	71 ⁰ _{-0.2}	315 ⁰ _{-1.0}	28 ^{+0.52} ₀	635	645	530	845	1250

(IM B3) 机座带底脚，端盖上无凸缘的电动机 Frame with foot and without flange on end shield

单位unit: mm

机座号 Frame	极数 Number of Poles	安装尺寸及公差 Mounting Dimension and Tolerances									外形尺寸 Overall Dimensions				
		A	B	C	D	E	F	G ^a	H	K ^b	AB	AC	AD	HD	L
315M	2	508	457	216 ± 4.0	65 ^{+0.030} _{+0.011}	140 ± 0.50	18 ⁰ _{-0.043}	58 ⁰ _{-0.2}	315 ⁰ _{-1.0}	28 ^{+0.52} ₀	635	645	530	845	1330
	4/6/8/10	508	457	216 ± 4.0	80 ^{+0.030} _{+0.011}	170 ± 0.50	22 ⁰ _{-0.052}	71 ⁰ _{-0.2}	315 ⁰ _{-1.0}	28 ^{+0.52} ₀	635	645	530	845	1360
315L	2	508	508	216 ± 4.0	65 ^{+0.030} _{+0.011}	140 ± 0.50	18 ⁰ _{-0.043}	58 ⁰ _{-0.2}	315 ⁰ _{-1.0}	28 ^{+0.52} ₀	635	645	530	845	1330
	4/6/8/10	508	508	216 ± 4.0	80 ^{+0.030} _{+0.011}	170 ± 0.50	22 ⁰ _{-0.052}	71 ⁰ _{-0.2}	315 ⁰ _{-1.0}	28 ^{+0.52} ₀	635	645	530	845	1360
315L3	2	508	508	216 ± 4.0	65 ^{+0.030} _{+0.011}	140 ± 0.50	18 ⁰ _{-0.043}	58 ⁰ _{-0.2}	315 ⁰ _{-1.0}	28 ^{+0.52} ₀	635	645	530	845	1460
	4/6/8/10	508	508	216 ± 4.0	80 ^{+0.030} _{+0.011}	170 ± 0.50	22 ⁰ _{-0.052}	71 ⁰ _{-0.2}	315 ⁰ _{-1.0}	28 ^{+0.52} ₀	635	645	530	845	1490
355M	2	610	560	254 ± 4.0	75 ^{+0.030} _{+0.011}	140 ± 0.50	20 ⁰ _{-0.052}	67.5 ⁰ _{-0.2}	355 ⁰ _{-1.0}	28 ^{+0.52} ₀	726	710	655	1000	1510
	4/6/8/10	610	560	254 ± 4.0	95 ^{+0.035} _{+0.013}	170 ± 0.50	25 ⁰ _{-0.052}	86 ⁰ _{-0.2}	355 ⁰ _{-1.0}	28 ^{+0.52} ₀	726	710	655	1000	1580
355L	2	610	630	254 ± 4.0	75 ^{+0.030} _{+0.011}	140 ± 0.50	20 ⁰ _{-0.052}	67.5 ⁰ _{-0.2}	355 ⁰ _{-1.0}	28 ^{+0.52} ₀	726	710	655	1000	1510
	4/6/8/10	610	630	254 ± 4.0	95 ^{+0.035} _{+0.013}	170 ± 0.50	25 ⁰ _{-0.052}	86 ⁰ _{-0.2}	355 ⁰ _{-1.0}	28 ^{+0.52} ₀	726	710	655	1000	1580
355L2	2	610	630	254 ± 4.0	75 ^{+0.030} _{+0.011}	140 ± 0.50	20 ⁰ _{-0.052}	67.5 ⁰ _{-0.2}	355 ⁰ _{-1.0}	28 ^{+0.52} ₀	726	710	655	1000	1660
	4/6/8/10	610	630	254 ± 4.0	95 ^{+0.035} _{+0.013}	170 ± 0.50	25 ⁰ _{-0.052}	86 ⁰ _{-0.2}	355 ⁰ _{-1.0}	28 ^{+0.52} ₀	726	710	655	1000	1690
355 ^a	2	630	800	224 ± 4.0	80 ^{+0.030} _{+0.011}	170 ± 0.50	22 ⁰ _{-0.052}	71 ⁰ _{-0.2}	355 ⁰ _{-1.0}	35 ^{+0.62} ₀	760	-	383	1135	1910
	4/6/8/10	630	800	224 ± 4.0	110 ^{+0.035} _{+0.013}	210 ± 0.57	28 ⁰ _{-0.052}	100 ⁰ _{-0.2}	355 ⁰ _{-1.0}	35 ^{+0.62} ₀	760	-	383	1135	1950
400	2	710	900	224 ± 4.0	85 ^{+0.035} _{+0.013}	170 ± 0.50	22 ⁰ _{-0.052}	76 ⁰ _{-0.2}	400 ⁰ _{-1.0}	35 ^{+0.62} ₀	840	-	430	1290	1960
	4/6/8/10	710	900	224 ± 4.0	120 ^{+0.035} _{+0.013}	210 ± 0.57	32 ⁰ _{-0.062}	109 ⁰ _{-0.2}	400 ⁰ _{-1.0}	35 ^{+0.62} ₀	840	-	430	1290	2000
450	2	800	1000	250 ± 4.0	95 ^{+0.035} _{+0.013}	170 ± 0.50	25 ⁰ _{-0.052}	86 ⁰ _{-0.2}	450 ⁰ _{-1.0}	42 ^{+0.62} ₀	990	-	485	1380	2160
	4/6/8/10	800	1000	250 ± 4.0	130 ^{+0.040} _{+0.015}	210 ± 0.57	32 ⁰ _{-0.062}	119 ⁰ _{-0.2}	450 ⁰ _{-1.0}	42 ^{+0.62} ₀	990	-	485	1380	2200

a G=D-GE, GE的极限偏差为^{+0.2}。

b K孔的位置度公差以轴伸的轴线为基准。

c 280L、315L3和355L2为同机座号增容设计规格外形尺寸。

d 355^a中a对应系列电动机型谱中机座号3551、3552、3553。

注：表中尺寸仅供参考，请以正式外形图为准。

a G=D-GE, the limited deviation of GE is ^{+0.2}.

b The position tolerance of K-hole is based on the axis of axle extension.

c 280L, 315L3 and 355L2 are outline dimensions of capacity-increasing design specifications of same frame.

d As per 355^a, a corresponds to the frame size of 3551, 3552 and 3553 in series motor type spectrum.

Note: The dimensions in the table are for reference only. Please refer to the formal outline drawing.



- H80 ~ 450(IM B35/V15) 机座带底脚，端盖上有凸缘的电动机
- H80 ~ 450(IM B35/V15) Frame with foot and flange on end shield

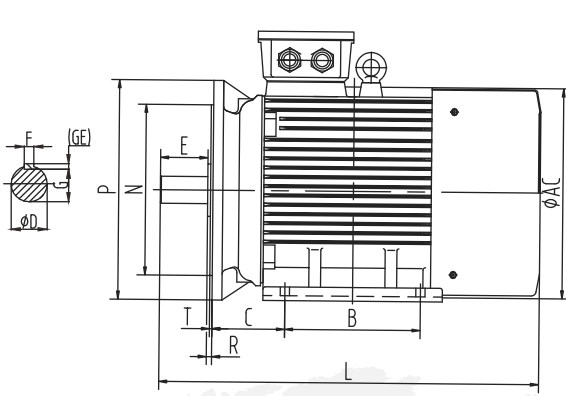

H80~200

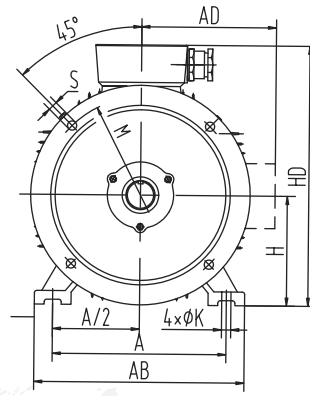

H80~200

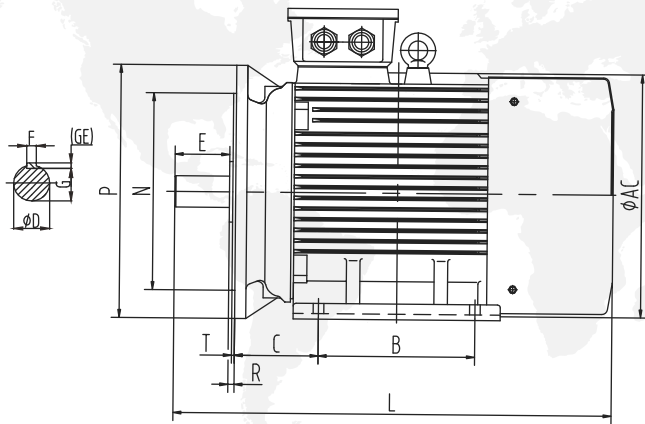

H225~355

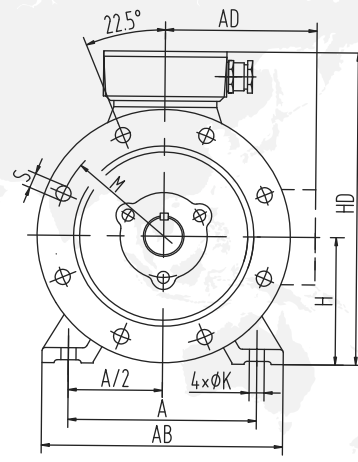

H225~355

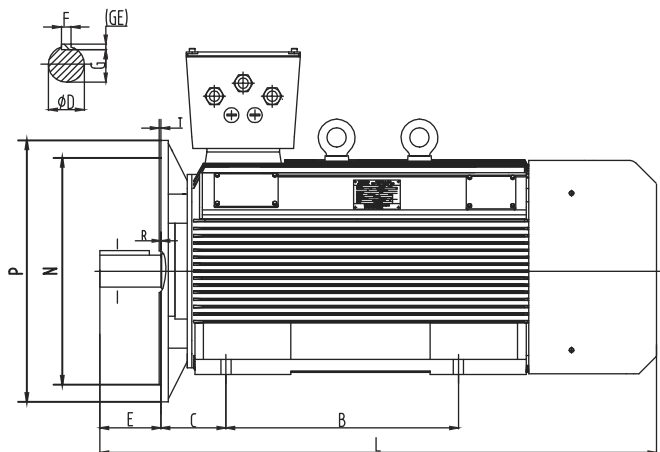

H355[°]~450

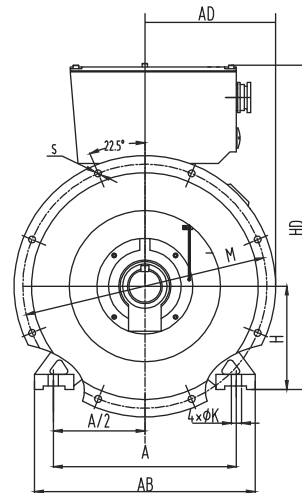

H355[°]~450

注：H80~90电机只有一个出线螺套，无吊环
Note: H80~90 motors have only one outlet screw sleeve and no lifting ring



(IM B35/V15) 机座带底脚，端盖上有凸缘的电动机 Frame with foot and flange on end shield

单位unit: mm

机座号 Frame	极数 Number of Poles	安装尺寸及公差 Mounting Dimension and Tolerances															外形尺寸 Overall Dimensios				
		A	B	C	D	E	F	G ^a	H	K ^b	M	N	P ^c	R ^d	S ^b	T	AB	AC	AD	HD	L
80M	2/4/6/8	125	100	50 ± 1.5	19 ^{+0.009} _{-0.004}	40 ± 0.31	6 ⁰ _{-0.03}	15.5 ⁰ _{-0.1}	80 ⁰ _{-0.5}	10 ^{+0.36} ₀	165	130 ^{+0.014} _{-0.011}	200	0 ± 1.5	12 ^{+0.43} ₀	3.5 ⁰ _{-0.12}	165	175	145	220	305
90S	2/4/6/8	140	125	56 ± 1.5	24 ^{+0.009} _{-0.004}	50 ± 0.31	8 ⁰ _{-0.036}	20 ⁰ _{-0.2}	90 ⁰ _{-0.5}	10 ^{+0.36} ₀	165	130 ^{+0.014} _{-0.011}	200	0 ± 1.5	12 ^{+0.43} ₀	3.5 ⁰ _{-0.12}	180	205	170	265	360
90L	2/4/6/8	140	125	56 ± 1.5	24 ^{+0.009} _{-0.004}	50 ± 0.31	8 ⁰ _{-0.036}	20 ⁰ _{-0.2}	90 ⁰ _{-0.5}	10 ^{+0.36} ₀	165	130 ^{+0.014} _{-0.011}	200	0 ± 1.5	12 ^{+0.43} ₀	3.5 ⁰ _{-0.12}	180	205	170	265	390
100L	2/4/6/8	160	140	63 ± 2.0	28 ^{+0.009} _{-0.004}	60 ± 0.37	8 ⁰ _{-0.036}	24 ⁰ _{-0.2}	100 ⁰ _{-0.5}	12 ^{+0.43} ₀	215	180 ^{+0.014} _{-0.011}	250	0 ± 2.0	14.5 ^{+0.43} ₀	4 ⁰ _{-0.12}	205	215	180	270	435
112M	2/4/6/8	190	140	70 ± 2.0	28 ^{+0.009} _{-0.004}	60 ± 0.37	8 ⁰ _{-0.036}	24 ⁰ _{-0.2}	112 ⁰ _{-0.5}	12 ^{+0.43} ₀	215	180 ^{+0.014} _{-0.011}	250	0 ± 2.0	14.5 ^{+0.43} ₀	4 ⁰ _{-0.12}	230	255	200	310	440
132S	2/4/6/8	216	140	89 ± 2.0	38 ^{+0.018} _{+0.002}	80 ± 0.37	10 ⁰ _{-0.036}	33 ⁰ _{-0.2}	132 ⁰ _{-0.5}	12 ^{+0.43} ₀	265	230 ^{+0.016} _{-0.013}	300	0 ± 2.0	14.5 ^{+0.43} ₀	4 ⁰ _{-0.12}	270	310	235	365	530
132M	4/6/8	216	178	89 ± 2.0	38 ^{+0.018} _{+0.002}	80 ± 0.37	10 ⁰ _{-0.036}	33 ⁰ _{-0.2}	132 ⁰ _{-0.5}	12 ^{+0.43} ₀	265	230 ^{+0.016} _{-0.013}	300	0 ± 2.0	14.5 ^{+0.43} ₀	4 ⁰ _{-0.12}	270	310	235	365	560
160M	2/4/6/8	254	210	108 ± 3.0	42 ^{+0.018} _{+0.002}	110 ± 0.43	12 ⁰ _{-0.043}	37 ⁰ _{-0.2}	160 ⁰ _{-0.5}	14.5 ^{+0.43} ₀	300	250 ^{+0.016} _{-0.013}	350	0 ± 3.0	18.5 ^{+0.52} ₀	5 ⁰ _{-0.12}	320	340	260	425	670
160L	2/4/6/8	254	254	108 ± 3.0	42 ^{+0.018} _{+0.002}	110 ± 0.43	12 ⁰ _{-0.043}	37 ⁰ _{-0.2}	160 ⁰ _{-0.5}	14.5 ^{+0.43} ₀	300	250 ^{+0.016} _{-0.013}	350	0 ± 3.0	18.5 ^{+0.52} ₀	5 ⁰ _{-0.12}	320	340	260	425	710
180M	2/4	279	241	121 ± 3.0	48 ^{+0.018} _{+0.002}	110 ± 0.43	14 ⁰ _{-0.043}	42.5 ⁰ _{-0.2}	180 ⁰ _{-0.5}	14.5 ^{+0.43} ₀	300	250 ^{+0.016} _{-0.013}	350	0 ± 3.0	18.5 ^{+0.52} ₀	5 ⁰ _{-0.12}	355	390	285	460	740
180L	4/6/8	279	279	121 ± 3.0	48 ^{+0.018} _{+0.002}	110 ± 0.43	14 ⁰ _{-0.043}	42.5 ⁰ _{-0.2}	180 ⁰ _{-0.5}	14.5 ^{+0.43} ₀	300	250 ^{+0.016} _{-0.013}	350	0 ± 3.0	18.5 ^{+0.52} ₀	5 ⁰ _{-0.12}	355	390	285	460	780
200L	2/4/6/8	318	305	133 ± 3.0	55 ^{+0.030} _{+0.011}	110 ± 0.43	16 ⁰ _{-0.043}	49 ⁰ _{-0.2}	200 ⁰ _{-0.5}	18.5 ^{+0.52} ₀	350	300 ± 0.016	400	0 ± 3.0	18.5 ^{+0.52} ₀	5 ⁰ _{-0.12}	395	445	320	520	880
225S	4/8	356	286	149 ± 4.0	60 ^{+0.030} _{+0.011}	140 ± 0.50	18 ⁰ _{-0.043}	53 ⁰ _{-0.2}	225 ⁰ _{-0.5}	18.5 ^{+0.52} ₀	400	350 ± 0.018	450	0 ± 4.0	18.5 ^{+0.52} ₀	5 ⁰ _{-0.12}	435	470	335	560	890
225M	2	356	311	149 ± 4.0	55 ^{+0.030} _{+0.011}	110 ± 0.43	16 ⁰ _{-0.043}	49 ⁰ _{-0.2}	225 ⁰ _{-0.5}	18.5 ^{+0.52} ₀	400	350 ± 0.018	450	0 ± 4.0	18.5 ^{+0.52} ₀	5 ⁰ _{-0.12}	435	470	335	560	900
	4/6/8	356	311	149 ± 4.0	60 ^{+0.030} _{+0.011}	140 ± 0.50	18 ⁰ _{-0.043}	53 ⁰ _{-0.2}	225 ⁰ _{-0.5}	18.5 ^{+0.52} ₀	400	350 ± 0.018	450	0 ± 4.0	18.5 ^{+0.52} ₀	5 ⁰ _{-0.12}	435	470	335	560	930
250M	2	406	349	168 ± 4.0	60 ^{+0.030} _{+0.011}	140 ± 0.50	18 ⁰ _{-0.043}	53 ⁰ _{-0.2}	250 ⁰ _{-0.5}	24 ^{+0.52} ₀	500	450 ± 0.020	550	0 ± 4.0	18.5 ^{+0.52} ₀	5 ⁰ _{-0.12}	490	550	390	635	990
	4/6/8	406	349	168 ± 4.0	65 ^{+0.030} _{+0.011}	140 ± 0.50	18 ⁰ _{-0.043}	58 ⁰ _{-0.2}	250 ⁰ _{-0.5}	24 ^{+0.52} ₀	500	450 ± 0.020	550	0 ± 4.0	18.5 ^{+0.52} ₀	5 ⁰ _{-0.12}	490	550	390	635	990
280S	2	457	368	190 ± 4.0	65 ^{+0.030} _{+0.011}	140 ± 0.50	18 ⁰ _{-0.043}	58 ⁰ _{-0.2}	280 ⁰ _{-1.0}	24 ^{+0.52} ₀	500	450 ± 0.020	550	0 ± 4.0	18.5 ^{+0.52} ₀	5 ⁰ _{-0.12}	550	630	435	705	990
	4/6/8	457	368	190 ± 4.0	75 ^{+0.030} _{+0.011}	140 ± 0.50	20 ⁰ _{-0.052}	67.5 ⁰ _{-0.2}	280 ⁰ _{-1.0}	24 ^{+0.52} ₀	500	450 ± 0.020	550	0 ± 4.0	18.5 ^{+0.52} ₀	5 ⁰ _{-0.12}	550	630	435	705	990
280M	2	457	419	190 ± 4.0	65 ^{+0.030} _{+0.011}	140 ± 0.50	18 ⁰ _{-0.043}	58 ⁰ _{-0.2}	280 ⁰ _{-1.0}	24 ^{+0.52} ₀	500	450 ± 0.020	550	0 ± 4.0	18.5 ^{+0.52} ₀	5 ⁰ _{-0.12}	550	630	435	705	1040
	4/6/8	457	419	190 ± 4.0	75 ^{+0.030} _{+0.011}	140 ± 0.50	20 ⁰ _{-0.052}	67.5 ⁰ _{-0.2}	280 ⁰ _{-1.0}	24 ^{+0.52} ₀	500	450 ± 0.020	550	0 ± 4.0	18.5 ^{+0.52} ₀	5 ⁰ _{-0.12}	550	630	435	705	1040
280L	2	457	419	190 ± 4.0	65 ^{+0.030} _{+0.011}	140 ± 0.50	18 ⁰ _{-0.043}	58 ⁰ _{-0.2}	280 ⁰ _{-1.0}	24 ^{+0.52} ₀	500	450 ± 0.020	550	0 ± 4.0	18.5 ^{+0.52} ₀	5 ⁰ _{-0.12}	550	630	435	705	1080
	4/6/8	457	419	190 ± 4.0	75 ^{+0.030} _{+0.011}	140 ± 0.50	20 ⁰ _{-0.052}	67.5 ⁰ _{-0.2}	280 ⁰ _{-1.0}	24 ^{+0.52} ₀	500	450 ± 0.020	550	0 ± 4.0	18.5 ^{+0.52} ₀	5 ⁰ _{-0.12}	550	630	435	705	1080
315S	2	508	406	216 ± 4.0	65 ^{+0.030} _{+0.011}	140 ± 0.50	18 ⁰ _{-0.043}	58 ⁰ _{-0.2}	315 ⁰ _{-1.0}	28 ^{+0.52} ₀	600	550 ± 0.022	660	0 ± 4.0	24 ^{+0.52} ₀	6 ⁰ _{-0.15}	635	645	530	845	1220
	4/6/8/10	508	406	216 ± 4.0	80 ^{+0.030} _{+0.011}	170 ± 0.50	20 ⁰ _{-0.052}	71 ⁰ _{-0.2}	315 ⁰ _{-1.0}	28 ^{+0.52} ₀	600	550 ± 0.022	660	0 ± 4.0	24 ^{+0.52} ₀	6 ⁰ _{-0.15}	635	645	530	845	1250



(IM B35/V15) 机座带底脚，端盖上有凸缘的电动机 Frame with foot and flange on end shield

单位unit: mm

机座号 Frame	极数 Number of Poles	安装尺寸及公差 Mounting Dimension and Tolerances															外形尺寸 Overall Dimensios				
		A	B	C	D	E	F	G ^a	H	K ^b	M	N	P ^c	R ^d	S ^b	T	AB	AC	AD	HD	L
315M	2	508	457	216±4.0	65 ^{+0.030} _{+0.011}	140±0.50	18 ⁰ _{-0.043}	58 ⁰ _{-0.2}	315 ⁰ _{-1.0}	28 ^{+0.52} ₀	600	550±0.022	660	0±4.0	24 ^{+0.52} ₀	6 ⁰ _{-0.15}	635	645	530	845	1330
	4/6/8/10	508	457	216±4.0	80 ^{+0.030} _{+0.011}	170±0.50	22 ⁰ _{-0.052}	71 ⁰ _{-0.2}	315 ⁰ _{-1.0}	28 ^{+0.52} ₀	600	550±0.022	660	0±4.0	24 ^{+0.52} ₀	6 ⁰ _{-0.15}	635	645	530	845	1360
315L	2	508	508	216±4.0	65 ^{+0.030} _{+0.011}	140±0.50	18 ⁰ _{-0.043}	58 ⁰ _{-0.2}	315 ⁰ _{-1.0}	28 ^{+0.52} ₀	600	550±0.022	660	0±4.0	24 ^{+0.52} ₀	6 ⁰ _{-0.15}	635	645	530	845	1330
	4/6/8/10	508	508	216±4.0	80 ^{+0.030} _{+0.011}	170±0.50	22 ⁰ _{-0.052}	71 ⁰ _{-0.2}	315 ⁰ _{-1.0}	28 ^{+0.52} ₀	600	550±0.022	660	0±4.0	24 ^{+0.52} ₀	6 ⁰ _{-0.15}	635	645	530	845	1360
315L3	2	508	508	216±4.0	65 ^{+0.030} _{+0.011}	140±0.50	18 ⁰ _{-0.043}	58 ⁰ _{-0.2}	315 ⁰ _{-1.0}	28 ^{+0.52} ₀	600	550±0.022	660	0±4.0	24 ^{+0.52} ₀	6 ⁰ _{-0.15}	635	645	530	845	1460
	4/6/8/10	508	508	216±4.0	80 ^{+0.030} _{+0.011}	170±0.50	22 ⁰ _{-0.052}	71 ⁰ _{-0.2}	315 ⁰ _{-1.0}	28 ^{+0.52} ₀	600	550±0.022	660	0±4.0	24 ^{+0.52} ₀	6 ⁰ _{-0.15}	635	645	530	845	1490
355M	2	610	560	254±4.0	75 ^{+0.030} _{+0.011}	140±0.50	20 ⁰ _{-0.052}	67.5 ⁰ _{-0.2}	355 ⁰ _{-1.0}	28 ^{+0.52} ₀	740	680±0.025	800	0±4.0	24 ^{+0.52} ₀	6 ⁰ _{-0.15}	726	710	655	1000	1510
	4/6/8/10	610	560	254±4.0	95 ^{+0.035} _{+0.013}	170±0.50	25 ⁰ _{-0.052}	86 ⁰ _{-0.2}	355 ⁰ _{-1.0}	28 ^{+0.52} ₀	740	680±0.025	800	0±4.0	24 ^{+0.52} ₀	6 ⁰ _{-0.15}	726	710	655	1000	1580
355L	2	610	630	254±4.0	75 ^{+0.030} _{+0.011}	140±0.50	20 ⁰ _{-0.052}	67.5 ⁰ _{-0.2}	355 ⁰ _{-1.0}	28 ^{+0.52} ₀	740	680±0.025	800	0±4.0	24 ^{+0.52} ₀	6 ⁰ _{-0.15}	726	710	655	1000	1510
	4/6/8/10	610	630	254±4.0	95 ^{+0.035} _{+0.013}	170±0.50	25 ⁰ _{-0.052}	86 ⁰ _{-0.2}	355 ⁰ _{-1.0}	28 ^{+0.52} ₀	740	680±0.025	800	0±4.0	24 ^{+0.52} ₀	6 ⁰ _{-0.15}	726	710	655	1000	1580
355L2	2	610	630	254±4.0	75 ^{+0.030} _{+0.011}	140±0.50	20 ⁰ _{-0.052}	67.5 ⁰ _{-0.2}	355 ⁰ _{-1.0}	28 ^{+0.52} ₀	740	680±0.025	800	0±4.0	24 ^{+0.52} ₀	6 ⁰ _{-0.15}	726	710	655	1000	1660
	4/6/8/10	610	630	254±4.0	95 ^{+0.035} _{+0.013}	170±0.50	25 ⁰ _{-0.052}	86 ⁰ _{-0.2}	355 ⁰ _{-1.0}	28 ^{+0.52} ₀	740	680±0.025	800	0±4.0	24 ^{+0.52} ₀	6 ⁰ _{-0.15}	726	710	655	1000	1690
355 ^a	2	630	800	224±4.0	80 ^{+0.030} _{+0.011}	170±0.50	22 ⁰ _{-0.052}	71 ⁰ _{-0.2}	355 ⁰ _{-1.0}	35 ^{+0.62} ₀	840	780±0.025	900	0±4.0	24 ^{+0.52} ₀	6 ⁰ _{-0.15}	760	-	450	1135	1910
	4/6/8/10	630	800	224±4.0	110 ^{+0.035} _{+0.013}	210±0.57	28 ⁰ _{-0.052}	100 ⁰ _{-0.2}	355 ⁰ _{-1.0}	35 ^{+0.62} ₀	840	780±0.025	900	0±4.0	24 ^{+0.52} ₀	6 ⁰ _{-0.15}	760	-	450	1135	1950
400	2	710	900	224±4.0	85 ^{+0.030} _{+0.011}	170±0.50	22 ⁰ _{-0.052}	76 ⁰ _{-0.2}	400 ⁰ _{-1.0}	35 ^{+0.62} ₀	940	880±0.028	1000	0±4.0	28 ^{+0.52} ₀	6 ⁰ _{-0.15}	840	-	500	1290	1960
	4/6/8/10	710	900	224±4.0	120 ^{+0.035} _{+0.013}	210±0.57	32 ⁰ _{-0.062}	109 ⁰ _{-0.2}	400 ⁰ _{-1.0}	35 ^{+0.62} ₀	940	880±0.028	1000	0±4.0	28 ^{+0.52} ₀	6 ⁰ _{-0.15}	840	-	500	1290	2000
450	2	800	1000	250±4.0	95 ^{+0.030} _{+0.011}	170±0.50	25 ⁰ _{-0.052}	86 ⁰ _{-0.2}	450 ⁰ _{-1.0}	42 ^{+0.62} ₀	1080	1000±0.028	1150	0±4.0	28 ^{+0.52} ₀	6 ⁰ _{-0.15}	990	-	575	1380	2160
	4/6/8/10	800	1000	250±4.0	130 ^{+0.040} _{+0.013}	210±0.57	32 ⁰ _{-0.062}	119 ⁰ _{-0.2}	450 ⁰ _{-1.0}	42 ^{+0.62} ₀	1080	1000±0.028	1150	0±4.0	28 ^{+0.52} ₀	6 ⁰ _{-0.15}	990	-	575	1380	2200

a G=D-GE, GE的极限偏差为^{+0.2}。

b K、S孔的位置度公差以轴伸的轴线为基准。

c P尺寸为最大极限值。

d R为凸缘配合面至轴伸肩的距离。

e 280L、315L3和355L2为YVFE3系列同机座号增容设计规格外形尺寸。

f 355^a中a对应系列电动机型谱中机座号3551、3552、3553。

注：表中尺寸仅供参考，请以正式外形图为准。

a G=D-GE, the limited deviation of GE is ^{+0.2}。

b The position tolerance of K and S holes is based on the axis of axle extension.

c P size is the maximum limit.

d R is the distance from the flange mating surface to the shoulder extension of the shaft.

f As per 355^a, a corresponds to the frame size of 3551, 3552 and 3553 in series motor type spectrum.

Note: The dimensions in the table are for reference only. Please refer to the formal outline drawing.



□ H80 ~ 355(IM B5/V1) 机座不带底脚，端盖上有凸缘的电动机

□ H80 ~ 355(IM B5/V1) Frame without foot and with flange on the end shield

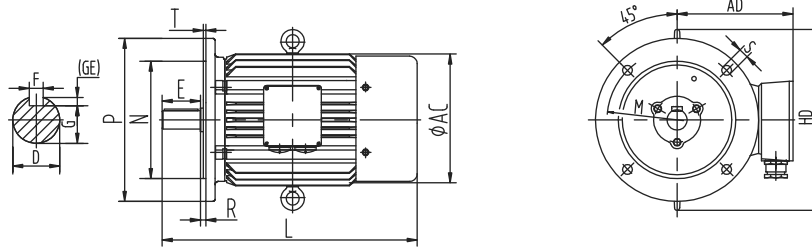

H80~160-IM B5/V1

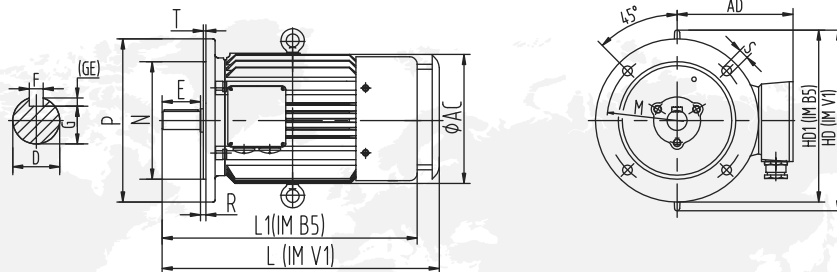

H225~280-IM B5/V1

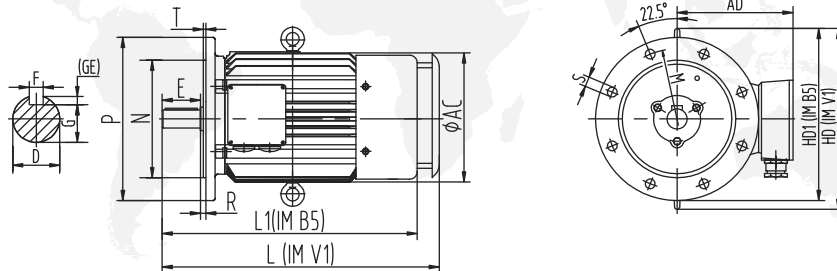

H225~280-IM B5/V1

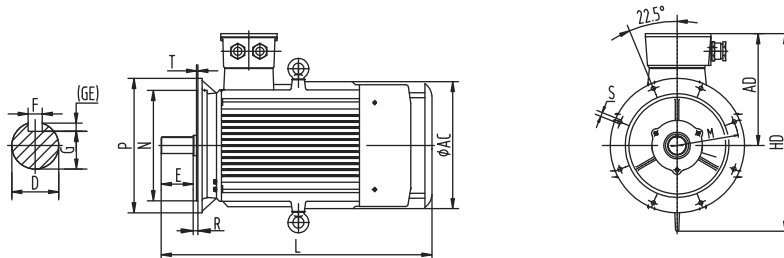

H315~355-IM V1

注：1、H80~90只有一个出线螺套，无吊环。

2、H132为顶出线机座。

3、H80~160标配风罩无防雨帽。

4、H100~280-IMB5为单吊环。

Note:1.H80~90 motors have only one outlet screw sleeve and no lifting ring.

2.H132 is the top outgoing machine stand.

3.H80~160 standard wind hood without rain cap.

4.H100~280-IM B5 are single rings.



(IM B5/V1)机座不带底脚，端盖上有凸缘的电动机 Frame without foot and with flange on the end shield

单位unit: mm

机座号 Frame	极数 Number of Poles	安装尺寸及公差 Mounting Dimension and Tolerances										外形尺寸 Overall Dimensios					
		D	E	F	G ^a	M	N	P ^c	R ^d	S ^b	T	AC	AD	HD1	HD	L1	L
80M	2/4/6/8	19 ^{+0.009} _{+0.004}	40 ± 0.31	6 ⁰ _{-0.03}	15.5 ⁰ _{-0.1}	165	130 ^{+0.014} _{-0.011}	200	0 ± 1.5	12 ⁰ ₀ ^{+0.43}	3.5 ⁰ _{-0.12}	175	145	-	-	305	305
90S	2/4/6/8	24 ^{+0.009} _{+0.004}	50 ± 0.31	8 ⁰ _{-0.036}	20 ⁰ _{-0.2}	165	130 ^{+0.014} _{-0.011}	200	0 ± 1.5	12 ⁰ ₀ ^{+0.43}	3.5 ⁰ _{-0.12}	205	170	-	-	360	395
90L	2/4/6/8	24 ^{+0.009} _{+0.004}	50 ± 0.31	8 ⁰ _{-0.036}	20 ⁰ _{-0.2}	165	130 ^{+0.014} _{-0.011}	200	0 ± 1.5	12 ⁰ ₀ ^{+0.43}	3.5 ⁰ _{-0.12}	205	170	-	-	390	425
100L	2/4/6/8	28 ^{+0.009} _{+0.004}	60 ± 0.37	8 ⁰ _{-0.036}	24 ⁰ _{-0.2}	215	180 ^{+0.014} _{-0.011}	250	0 ± 2.0	14.5 ⁰ ₀ ^{+0.43}	4 ⁰ _{-0.12}	215	180	-	240	435	435
112M	2/4/6/8	28 ^{+0.009} _{+0.004}	60 ± 0.37	8 ⁰ _{-0.036}	24 ⁰ _{-0.2}	215	180 ^{+0.014} _{-0.011}	250	0 ± 2.0	14.5 ⁰ ₀ ^{+0.43}	4 ⁰ _{-0.12}	255	200	-	275	440	475
132S	2/4/6/8	38 ^{+0.018} _{+0.002}	80 ± 0.37	10 ⁰ _{-0.036}	33 ⁰ _{-0.2}	265	230 ^{+0.016} _{-0.013}	300	0 ± 2.00	14.5 ⁰ ₀ ^{+0.43}	4 ⁰ _{-0.12}	310	230	-	335	530	530
132M	2/4/6/8	38 ^{+0.018} _{+0.002}	80 ± 0.37	10 ⁰ _{-0.036}	33 ⁰ _{-0.2}	265	230 ^{+0.016} _{-0.013}	300	0 ± 2.0	14.5 ⁰ ₀ ^{+0.43}	4 ⁰ _{-0.12}	310	230	-	335	560	560
160M	2/4/6/8	42 ^{+0.018} _{+0.002}	110 ± 0.43	12 ⁰ _{-0.043}	37 ⁰ _{-0.2}	300	250 ^{+0.016} _{-0.013}	350	0 ± 3.0	18.5 ⁰ ₀ ^{+0.52}	5 ⁰ _{-0.12}	340	260	390	460	670	730
160L	2/4/6/8	42 ^{+0.018} _{+0.002}	110 ± 0.43	12 ⁰ _{-0.043}	37 ⁰ _{-0.2}	300	250 ^{+0.016} _{-0.013}	350	0 ± 3.0	18.5 ⁰ ₀ ^{+0.52}	5 ⁰ _{-0.12}	340	260	390	460	710	760
180M	2/4/6/8	48 ^{+0.018} _{+0.002}	110 ± 0.43	14 ⁰ _{-0.043}	42.5 ⁰ _{-0.2}	300	250 ^{+0.016} _{-0.013}	350	0 ± 3.0	18.5 ⁰ ₀ ^{+0.52}	5 ⁰ _{-0.12}	390	285	435	505	740	825
180L	2/4/6/8	48 ^{+0.018} _{+0.002}	110 ± 0.43	14 ⁰ _{-0.043}	42.5 ⁰ _{-0.2}	300	250 ^{+0.016} _{-0.013}	350	0 ± 3.0	18.5 ⁰ ₀ ^{+0.52}	5 ⁰ _{-0.12}	390	285	436	505	780	845
200L	2/4/6/8	55 ^{+0.030} _{+0.011}	110 ± 0.43	16 ⁰ _{-0.043}	49 ⁰ _{-0.2}	350	300 ± 0.016	400	0 ± 3.0	18.5 ⁰ ₀ ^{+0.52}	5 ⁰ _{-0.12}	445	320	495	565	880	940
225S	2/4/6/8	60 ^{+0.030} _{+0.011}	140 ± 0.50	18 ⁰ _{-0.043}	53 ⁰ _{-0.2}	400	350 ± 0.018	450	0 ± 4.0	18.5 ⁰ ₀ ^{+0.52}	5 ⁰ _{-0.12}	495	350	550	625	890	945
225M	2	55 ^{+0.030} _{+0.011}	110 ± 0.43	16 ⁰ _{-0.043}	49 ⁰ _{-0.2}	400	350 ± 0.018	450	0 ± 4.0	18.5 ⁰ ₀ ^{+0.52}	5 ⁰ _{-0.12}	495	350	550	625	900	945
	4/6/8	60 ^{+0.030} _{+0.011}	140 ± 0.50	18 ⁰ _{-0.043}	53 ⁰ _{-0.2}	400	350 ± 0.018	450	0 ± 4.0	18.5 ⁰ ₀ ^{+0.52}	5 ⁰ _{-0.12}	495	350	550	625	930	975
250M	2	60 ^{+0.030} _{+0.011}	140 ± 0.50	18 ⁰ _{-0.043}	53 ⁰ _{-0.2}	500	450 ± 0.020	550	0 ± 4.0	18.5 ⁰ ₀ ^{+0.52}	5 ⁰ _{-0.12}	550	390	615	670	990	1095
	4/6/8	65 ^{+0.030} _{+0.011}	140 ± 0.50	18 ⁰ _{-0.043}	58 ⁰ _{-0.2}	500	450 ± 0.020	550	0 ± 4.0	18.5 ⁰ ₀ ^{+0.52}	5 ⁰ _{-0.12}	550	390	615	670	990	1095
280S	2	65 ^{+0.030} _{+0.011}	140 ± 0.50	18 ⁰ _{-0.043}	58 ⁰ _{-0.2}	500	450 ± 0.020	550	0 ± 4.0	18.5 ⁰ ₀ ^{+0.52}	5 ⁰ _{-0.12}	630	435	640	745	990	1155
	4/6/8	75 ^{+0.030} _{+0.011}	140 ± 0.50	20 ⁰ _{-0.052}	67.5 ⁰ _{-0.2}	500	450 ± 0.020	550	0 ± 4.0	18.5 ⁰ ₀ ^{+0.52}	5 ⁰ _{-0.12}	630	435	640	745	990	1155
280M	2	65 ^{+0.030} _{+0.011}	140 ± 0.50	18 ⁰ _{-0.043}	58 ⁰ _{-0.2}	500	450 ± 0.020	550	0 ± 4.0	18.5 ⁰ ₀ ^{+0.52}	5 ⁰ _{-0.12}	630	435	640	745	1040	1195
	4/6/8	75 ^{+0.030} _{+0.011}	140 ± 0.50	20 ⁰ _{-0.052}	67.5 ⁰ _{-0.2}	500	450 ± 0.020	550	0 ± 4.0	18.5 ⁰ ₀ ^{+0.52}	5 ⁰ _{-0.12}	630	435	640	745	1040	1195
280L	2	65 ^{+0.030} _{+0.011}	140 ± 0.50	18 ⁰ _{-0.043}	58 ⁰ _{-0.1}	500	450 ± 0.020	550	0 ± 4.0	18.5 ⁰ ₀ ^{+0.52}	5 ⁰ _{-0.12}	630	435	640	705	1080	1235
	4/6	75 ^{+0.030} _{+0.011}	140 ± 0.50	20 ⁰ _{-0.052}	67.5 ⁰ _{-0.2}	500	450 ± 0.020	550	0 ± 4.0	18.5 ⁰ ₀ ^{+0.52}	5 ⁰ _{-0.12}	630	435	640	705	1080	1235
315S	2	65 ^{+0.030} _{+0.011}	140 ± 0.50	18 ⁰ _{-0.043}	58 ⁰ _{-0.2}	600	550 ± 0.022	660	0 ± 4.0	24 ⁰ ₀ ^{+0.52}	6 ⁰ _{-0.12}	645	630	-	980	-	1350
	4/6/8/10	80 ^{+0.030} _{+0.011}	170 ± 0.50	22 ⁰ _{-0.052}	71 ⁰ _{-0.2}	600	550 ± 0.022	660	0 ± 4.0	24 ⁰ ₀ ^{+0.52}	6 ⁰ _{-0.12}	645	630	-	980	-	1380



(IM B5/V1)机座不带底脚，端盖上有凸缘的电动机 Frame without foot and with flange on the end shield

单位unit: mm

机座号 Frame	极数 Number of Poles	安装尺寸及公差 Mounting Dimension and Tolerances										外形尺寸 Overall Dimensions					
		D	E	F	G ^a	M	N	P ^c	R ^d	S ^b	T	AC	AD	HD1	HD	L1	L
315M	2	65 ^{+0.030} _{+0.011}	140 ± 0.50	18 ⁰ _{-0.043}	58 ⁰ _{-0.2}	600	550 ± 0.022	660	0 ± 4.0	24 ^{+0.52} ₀	6 ⁰ _{-0.12}	645	630	-	980	-	1450
	4/6/8/10	80 ^{+0.030} _{+0.011}	170 ± 0.50	22 ⁰ _{-0.052}	71 ⁰ _{-0.2}	600	550 ± 0.022	660	0 ± 4.0	24 ^{+0.52} ₀	6 ⁰ _{-0.12}	645	630	-	980	-	1480
315L	2	65 ^{+0.030} _{+0.011}	140 ± 0.50	18 ⁰ _{-0.043}	58 ⁰ _{-0.2}	600	550 ± 0.022	660	0 ± 4.0	24 ^{+0.52} ₀	6 ⁰ _{-0.12}	645	630	-	980	-	1450
	4/6/8/10	80 ^{+0.030} _{+0.011}	170 ± 0.50	22 ⁰ _{-0.052}	71 ⁰ _{-0.2}	600	550 ± 0.022	660	0 ± 4.0	24 ^{+0.52} ₀	6 ⁰ _{-0.12}	645	630	-	980	-	1480
355L3	2	65 ^{+0.030} _{+0.011}	140 ± 0.50	18 ⁰ _{-0.043}	58 ⁰ _{-0.2}	600	550 ± 0.022	660	0 ± 4.0	24 ^{+0.52} ₀	6 ⁰ _{-0.12}	645	630	-	980	-	1580
	4/6/8/10	80 ^{+0.030} _{+0.011}	170 ± 0.50	22 ⁰ _{-0.052}	71 ⁰ _{-0.2}	600	550 ± 0.022	660	0 ± 4.0	24 ^{+0.52} ₀	6 ⁰ _{-0.12}	645	630	-	980	-	1610
355M	2	75 ^{+0.030} _{+0.011}	140 ± 0.50	20 ⁰ _{-0.052}	67.5 ⁰ _{-0.2}	740	680 ± 0.025	800	0 ± 4.0	24 ^{+0.52} ₀	6 ⁰ _{-0.12}	710	660	-	1131	-	1640
	4/6/8/10	95 ^{+0.035} _{+0.013}	170 ± 0.50	25 ⁰ _{-0.052}	86 ⁰ _{-0.2}	740	680 ± 0.025	800	0 ± 4.0	24 ^{+0.52} ₀	6 ⁰ _{-0.12}	710	660	-	1131	-	1710
355L	2	75 ^{+0.030} _{+0.011}	140 ± 0.50	20 ⁰ _{-0.052}	67.5 ⁰ _{-0.2}	740	680 ± 0.025	800	0 ± 4.0	24 ^{+0.52} ₀	6 ⁰ _{-0.12}	710	660	-	1131	-	1640
	4/6/8/10	95 ^{+0.035} _{+0.013}	170 ± 0.50	25 ⁰ _{-0.052}	86 ⁰ _{-0.2}	740	680 ± 0.025	800	0 ± 4.0	24 ^{+0.52} ₀	6 ⁰ _{-0.12}	710	660	-	1131	-	1710

- a G=D-GE, GE的极限偏差为^{+0.2}₀。
- b K、S孔的位置度公差以轴伸的轴线为基准。
- c P尺寸为最大极限值。
- d R为凸缘配合面至轴伸肩的距离。
- e 280L、315L3和355L2为同机座号增容设计规格外形尺寸。

注：表中尺寸仅供参考，请以正式外形图为准。

- a G=D-GE, the limited deviation of GE is ^{+0.2}₀.
 - b The position tolerance of K and S holes is based on the axis of axle extension.
 - c. P size is the maximum limit.
 - d. R is the distance from the flange mating surface to the shoulder extension of the shaft.
 - e 280L, 315L3 and 355L2 are outline dimensions of capacity-increasing design specifications of same frame size.
- Note: The dimensions in the table are for reference only. Please refer to the formal outline drawing.



订购指南 Ordering Instruments

➤ 电压 / Rated Voltage

380V 400V 415V 660V 690V 220/380V 380/660V 400/690V 其他 / Others

➤ 频率 / Frequency

50Hz 60Hz 其他 / Others

➤ 防护等级 / Protection Grade

IP55 其他 / Others

➤ 热分级 / Insulation Grade:

155 (F) ; 180 (H) ; 其他 / Others

➤ 安装型式 / Mounting Type

IM B3 IM B35 IM B5 IM V1 其他 / Others

➤ 运行环境 / Working Condition:

户内 / indoor; 户外 / outdoor; 环境温度 / Ambient temperature; 海拔高度 / Aititude;
防腐 / anti corrosion; 其他 / Others

➤ 工作制 / Duty:

S1; 其他 / Others

➤ 负载的设备类型 / Onload Equipment Type:

风机; 水泵; 压缩机; 其他 / Others

➤ 电机与被驱动设备的连接方式 / Coupling Type:

联轴器; 皮带; 其他 / Others

➤ 旋转方向 / Rotation Direction:

顺时针 / Clockwise; 逆时针 / Counterclockwise; 双向 / Two-way.

➤ 接线盒位置 / location of terminal box:

电机顶部朝右 (从轴伸端视之) / Right, upper side of motor (viewing from shaft extension end) ;
其他 / Others

注: 1.如果用户的要求超过本系列电动机标准形式的规定, 请于本公司联系协商。

2.变频电机强迫风机电机默认为380V。如需随异电压主机调整, 订货时必须注明。

Note: 1.If customers have special requirement, please contact us for special design.

2.The default voltage of variable frequency motor forced-ventilated fan is 380V, which needs to be adjusted along with abnormal voltage. Please note during ordering.



西玛电机防伪查询操作指南

Simo Motor Anti-Counterfeiting Query & Operation Instruction

➤ 为了打击和严防假冒“西玛”牌电机，自2018年1月1日起西安泰富西玛电机有限公司（原西安电机厂）针对基本系列产品铭牌上全面启用防伪二维码标识（铭牌右下角）

I. In order to combat and prevent counterfeit "Simo" brand motors, from January 1, 2018, Xi'an Tech Full Simo Motor Co., Ltd. (formerly Xi'an Motor Factory) has fully enabled the anti-counterfeit QR code identification on the nameplates of basic products (right of the nameplate (Bottom corner) as shown in Figure 1.

➤ 防伪查询II Anti-Counterfeiting Query

1) 扫一扫查询、Scan query

打开手机微信/支付宝，扫一扫功能，对准您产品铭牌上右下角的二维码扫一扫，核对铭牌上的型号、出厂编号信息等与扫描显示的信息是否一致，来辨别真伪。如下图2，图3所示：

Open the mobile WeChat / Alipay-scan function- scan the QR code on the lower right corner of your product nameplate, and check whether the type, factory number and other information on the nameplate are consistent with the information displayed on the scan to identify authenticity. As shown in Figure 2 and Figure 3:

扫描铭牌二维码：

Scan the QR code of the nameplate:

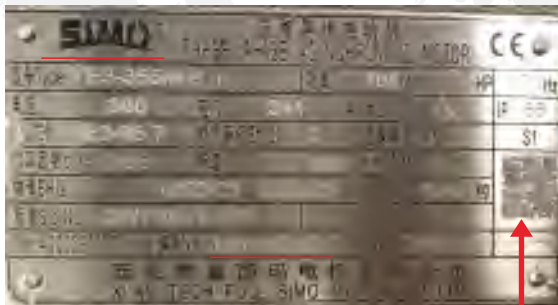

扫一扫

扫描显示信息

scan display information



核对信息 Checking information

- ☞ 铭牌型号与显示型号信息核对；
- ☞ 铭牌编号与显示出厂编号核对；
- ☞ 核对除上述以外的其他信息。

Check the nameplate model and display model information;
Check the nameplate number and display the factory number;
Check other information besides the above.

2) 手动输入查询（2019年出厂电机）

a. 登录西玛电机官网：www.simo.com.cn 首页右上角，点击【防伪查询】按钮，输入相应的信息，点击【查询】按钮。

b. 关注微信公众号：【西玛电机】，点击菜单【防伪查询】，输入相应的信息，点击【查询】按钮

2) Manual input query (factory motors in 2019)

a. Login to the official website of www.simo.com.cn, in the upper right corner of the homepage, click the [Anti-counterfeiting query] button, enter the corresponding information, and click the [Query] button.

b. Follow WeChat OfficialAccount: [Xima Electric], click the menu [Anti-counterfeiting query], enter the corresponding information, and click the [Query] button

合作共赢 引领未来





西安西玛电机有限公司

XI'AN SIMO MOTOR CO.,LTD

邮箱/Email: sales@simo.com.cn

手机/ Mobile: +86-182 0923 3121

电话/ Tel: +86-29-86171119

传真/ Fax: +86-29-86171116

官网/Website: www.simomotor.com.cn

地址/Address: 西安市经济技术开发区明光路159号
No.159, Mingguang Road, Economical

& Technology Zone, Xi' an, Shaanxi

2021年10月印